

## ISO7821x High-Performance, 8000 V<sub>PK</sub> Reinforced Dual Channel Digital Isolator

### 1 Features

- Signaling Rate: Up to 100 Mbps
- Wide Supply Range: 2.25 V to 5.5 V
- 2.25 V to 5.5 V Level Translation
- Wide Temperature Range: –55°C to 125°C
- Low Power Consumption, Typical 1.8 mA per Channel at 1 Mbps
- Low Propagation Delay: 11 ns Typical (5 V Supplies)
- Industry leading CMTI(Min): ±100 kV/μs
- Robust Electromagnetic Compatibility (EMC)
- System-Level ESD, EFT, and Surge Immunity
- Low Emissions
- Isolation Barrier Life: > 25 Years
- SOIC-16 Wide Body (DW) and Extra-Wide Body (DWW) Package Options
- Safety and Regulatory Approvals:
  - 8000 V<sub>PK</sub> Reinforced Isolation per DIN V VDE V 0884-10 (VDE V 0884-10):2006-12
  - 5.7 kV<sub>RMS</sub> Isolation for 1 minute per UL 1577
  - CSA Component Acceptance Notice 5A, IEC 60950-1 and IEC 60601-1 End Equipment Standards
  - CQC Certification per GB4943.1-2011
  - TUV Certification per EN 61010-1 and EN 60950-1
  - All DW Package Certifications Complete; DWW Package Certifications Complete per UL, TUV and Planned for VDE, CSA, and CQC

### 2 Applications

- Industrial Automation
- Motor Control
- Power Supplies
- Solar Inverters
- Medical Equipment
- Hybrid Electric Vehicles

### 3 Description

The ISO7821 is a high-performance, dual-channel digital isolator with 8000 V<sub>PK</sub> isolation voltage. This device has reinforced isolation certifications according to VDE, CSA, CQC, and TUV. The isolator provides high electromagnetic immunity and low emissions at low power consumption, while isolating CMOS or LVC MOS digital I/O's. Each isolation channel has a logic input and output buffer separated by silicon dioxide (SiO<sub>2</sub>) insulation barrier. ISO7821 has one forward and one reverse-direction channel. If the input power or signal is lost, default output is 'high' for the ISO7821 and 'low' for the ISO7821F device. Used in conjunction with isolated power supplies, this device prevents noise currents on a data bus or other circuits from entering the local ground and interfering with or damaging sensitive circuitry. Through innovative chip design and layout techniques, electromagnetic compatibility of ISO7821 has been significantly enhanced to ease system-level ESD, EFT, Surge and Emissions compliance. ISO7821 is available in 16-pin SOIC wide-body (DW) and extra-wide body (DWW) packages. The DWW package option comes with enable pins which can be used to put the respective outputs in high impedance for multi-master driving applications and to reduce power consumption.

#### Device Information<sup>(1)</sup>

PART NUMBER	PACKAGE	BODY SIZE (NOM)
ISO7821, ISO7821F	SOIC, DW (16)	10.30 mm x 7.50 mm
	Extra wide SOIC, DWW (16)	10.30 mm x 14.0 mm

(1) For all available packages, see the orderable addendum at the end of the datasheet.

#### Simplified Schematic

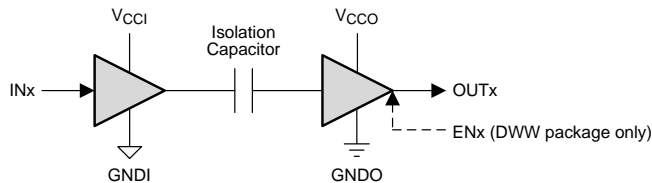

(1) V<sub>CCI</sub> and GNDI are supply and ground connections respectively for the input channels.

(2) V<sub>CCO</sub> and GNDO are supply and ground connections respectively for the output channels.



## Table of Contents

<b>1 Features</b> .....	<b>1</b>	8.1 Overview .....	<b>16</b>
<b>2 Applications</b> .....	<b>1</b>	8.2 Functional Block Diagram .....	<b>16</b>
<b>3 Description</b> .....	<b>1</b>	8.3 Feature Description .....	<b>17</b>
<b>4 Revision History</b> .....	<b>2</b>	8.4 Device Functional Modes .....	<b>21</b>
<b>5 Pin Configuration and Functions</b> .....	<b>5</b>	<b>9 Application and Implementation</b> .....	<b>23</b>
<b>6 Specifications</b> .....	<b>6</b>	9.1 Application Information .....	<b>23</b>
6.1 Absolute Maximum Ratings .....	<b>6</b>	9.2 Typical Application .....	<b>23</b>
6.2 ESD Ratings .....	<b>6</b>	<b>10 Power Supply Recommendations</b> .....	<b>25</b>
6.3 Recommended Operating Conditions .....	<b>6</b>	<b>11 Layout</b> .....	<b>26</b>
6.4 Thermal Information .....	<b>7</b>	11.1 PCB Material .....	<b>26</b>
6.5 Power Dissipation Characteristics .....	<b>7</b>	11.2 Layout Guidelines .....	<b>26</b>
6.6 Electrical Characteristics, 5 V .....	<b>8</b>	11.3 Layout Example .....	<b>26</b>
6.7 Electrical Characteristics, 3.3 V .....	<b>9</b>	<b>12 Device and Documentation Support</b> .....	<b>27</b>
6.8 Electrical Characteristics, 2.5 V .....	<b>10</b>	12.1 Documentation Support .....	<b>27</b>
6.9 Switching Characteristics, 5 V .....	<b>11</b>	12.2 Related Links .....	<b>27</b>
6.10 Switching Characteristics, 3.3 V .....	<b>11</b>	12.3 Community Resources .....	<b>27</b>
6.11 Switching Characteristics, 2.5 V .....	<b>12</b>	12.4 Trademarks .....	<b>27</b>
6.12 Typical Characteristics .....	<b>13</b>	12.5 Electrostatic Discharge Caution .....	<b>27</b>
<b>7 Parameter Measurement Information</b> .....	<b>14</b>	12.6 Glossary .....	<b>27</b>
<b>8 Detailed Description</b> .....	<b>16</b>	<b>13 Mechanical, Packaging, and Orderable Information</b> .....	<b>27</b>

## 4 Revision History

NOTE: Page numbers for previous revisions may differ from page numbers in the current version.

<b>Changes from Revision E (December 2015) to Revision F</b>	<b>Page</b>
• Changed the Safety and Regulatory Approvals list of <a href="#">Features</a> .....	<b>1</b>
• Added <a href="#">Features</a> "TUV Certification per EN 61010-1 and EN 60950-1" .....	<b>1</b>
• Changed text in the first paragraph of the <a href="#">Description</a> From: "certifications according to VDE, CSA, and CQC". To: "certifications according to VDE, CSA, CQC, and TUV." .....	<b>1</b>
• Added Note 1 to <a href="#">Table 2</a> .....	<b>18</b>
• Added TUV to the <a href="#">Regulatory Information</a> section and <a href="#">Table 4</a> . Deleted Note 1 in <a href="#">Table 4</a> .....	<b>19</b>
• Changed <a href="#">Figure 15</a> .....	<b>22</b>

<b>Changes from Revision D (July 2015) to Revision E</b>	<b>Page</b>
• Changed <a href="#">Features</a> From: 8000 V <sub>PK</sub> V <sub>IOTM</sub> and 2121 V <sub>PK</sub> V <sub>IORM</sub> Reinforced..To: 8000 V <sub>PK</sub> Reinforced.....	<b>1</b>
• Added <a href="#">Features</a> : DW Package Certifications Complete; DWW Certifications Planned .....	<b>1</b>
• Added text to the Description: and extra-wide body (DWW) packages... ..	<b>1</b>
• Added package: Extra wide SOIC, DWW (16) to the <a href="#">Device Information</a> table .....	<b>1</b>
• Added the DWW pinout image .....	<b>5</b>
• Added the DWW package to the <a href="#">Thermal Information</a> .....	<b>7</b>
• Changed the MIN value of CMTI in <a href="#">Electrical Characteristics, 5 V</a> table From: 70 To: 100 kV/μs, deleted the TYP value of 100 kV/μs .....	<b>8</b>
• Added the DW package value to the Supply Current section of the <a href="#">Electrical Characteristics, 5 V</a> .....	<b>8</b>
• Added the DWW package value to the Supply Current section of the <a href="#">Electrical Characteristics, 5 V</a> .....	<b>8</b>
• Changed the MIN value of CMTI in <a href="#">Electrical Characteristics, 3.3 V</a> table From: 70 To: 100 kV/μs, deleted the TYP value of 100 kV/μs .....	<b>9</b>
• Added the DW package value to the Supply Current section of the <a href="#">Electrical Characteristics, 3.3 V</a> .....	<b>9</b>
• Added the DWW package value to the Supply Current section of the <a href="#">Electrical Characteristics, 3.3 V</a> .....	<b>9</b>

• Changed the MIN value of CMTI in <a href="#">Electrical Characteristics, 2.5 V</a> table From: 70 To: 100 kV/μs, deleted the TYP value of 100 kV/μs .....	10
• Added the DW package value to the Supply Current section of the <a href="#">Electrical Characteristics, 2.5 V</a> .....	10
• Added the DWW package value to the Supply Current section of the <a href="#">Electrical Characteristics, 2.5 V</a> .....	10
• Added t <sub>PHZ</sub> , t <sub>PLZ</sub> , t <sub>PZH</sub> , and t <sub>PZL</sub> to <a href="#">Switching Characteristics, 3.3 V</a> .....	11
• Added t <sub>PHZ</sub> , t <sub>PLZ</sub> , t <sub>PZH</sub> , and t <sub>PZL</sub> to <a href="#">Switching Characteristics, 2.5 V</a> .....	12
• Added <a href="#">Figure 8</a> .....	14
• Added the DWW package to <a href="#">Table 1</a> .....	17
• Changed C <sub>IO</sub> typ value From: 2 To 1 pF in <a href="#">Table 1</a> .....	17
• Added the DWW package to <a href="#">Table 2</a> .....	18
• Changed Parameter information and added the DWW package information in <a href="#">Table 3</a> .....	18
• Added the DWW package information to <a href="#">Table 4</a> .....	19
• added DWW-16 package options to <a href="#">Table 5</a> .....	20
• Changed <a href="#">Table 6</a> .....	21
• Added text to the <a href="#">Application Information</a> section: "isolation voltage per UL 1577." .....	23

**Changes from Revision C (May 2015) to Revision D**
**Page**

• Added device ISO7821F to the datasheet .....	1
• Changed the <a href="#">Description</a> to include: "default output is 'high' for the ISO7821 device and 'low' for the ISO7821F device. ....	1
• Changed the <a href="#">Simplified Schematic</a> .....	1
• Changed t <sub>PLH</sub> and t <sub>PHL</sub> From: 5.5 V to 5 V in <a href="#">Figure 6</a> .....	13
• Changed <a href="#">Figure 9</a> .....	15
• Changed the <a href="#">Functional Block Diagram</a> .....	16
• Changed <a href="#">Table 1</a> title From: <i>IEC Insulation and Safety-Related Specifications for DW-16 Package</i> To: <i>Package Insulation and Safety-Related Specifications</i> .....	17
• Changed <a href="#">Figure 13</a> , Added <a href="#">Figure 14</a> .....	20

**Changes from Revision B (April 2015) to Revision C**
**Page**

• Changed From: V <sub>CC1</sub> and V <sub>CC2</sub> To: V <sub>CC1</sub> and V <sub>CC0</sub> , GND1 and GND2 To: GND1 and GND0 and added Notes 1 and 2 in the <a href="#">Simplified Schematic</a> .....	1
• Changed the MIN value of CMTI in <a href="#">Electrical Characteristics, 5 V</a> table From: 50 To: 70 kV/μs .....	8
• Changed the MIN value of CMTI in <a href="#">Electrical Characteristics, 3.3 V</a> table From: 50 To: 70 kV/μs .....	9
• Changed the MIN value of CMTI in <a href="#">Electrical Characteristics, 2.5 V</a> table From: 50 To: 70 kV/μs .....	10
• Added sentence "If the EN pin is available and low then the output goes to high impedance." to the <a href="#">Overview</a> section .....	16
• Changed the <a href="#">Functional Block Diagram</a> to include the EN pin on the Receiver side .....	16
• Changed the Installation classification of the <a href="#">Table 3</a> to include DW package information.....	18
• Changed "ISO782W functional modes" To: "ISO7821DW functional modes" in <a href="#">Device Functional Modes</a> .....	21
• Changed <a href="#">Table 6</a> title From: "Functional Table" To: "ISO7821DW Function Table".....	21
• Added the <a href="#">Device I/O Schematics</a> section .....	22
• Changed device number ISO7821 To: ISO7821DW in <a href="#">Figure 17</a> .....	24

<b>Changes from Revision A (December 2014) to Revision B</b>	<b>Page</b>
• Changed the document title From: "Channel Digital Isolator" To: "Channel 1/1 Digital Isolator" .....	1
• Added <i>Features</i> : 2.25 V to 5.5 V Level Translation .....	1
• Changed the Safety and Regulatory Approvals list of <i>Features</i> .....	1
• Changed text in the <i>Description</i> From: "This device is being reviewed for reinforced isolation certification by VDE and CSA. To: "This device has reinforced isolation certifications according to VDE, CSA, and CQC." .....	1
• Added Note (3) to the <i>Absolute Maximum Ratings</i> <sup>(1)</sup> table .....	6
• Changed From: $V_{CCX}$ To: $V_{CCO}$ In $I_{OH}$ and $I_{OL}$ of the <i>Recommended Operating Conditions</i> table .....	6
• Changed From: $V_{CCX}$ To: $V_{CCI}$ In $V_{IH}$ and $V_{IL}$ of the <i>Recommended Operating Conditions</i> table .....	6
• Changed Note (1) of the <i>Recommended Operating Conditions</i> table .....	6
• Added the <i>Power Dissipation Characteristics</i> table .....	7
• Changed From: $V_{CCX}$ To: $V_{CCO}$ In $V_{OH}$ of the <i>Electrical Characteristics, 5 V</i> table .....	8
• Changed From: $V_{CCX}$ To: $V_{CCO}$ In $V_{I(HYS)}$ of the <i>Electrical Characteristics, 5 V</i> table .....	8
• Changed From: $V_{CCX}$ To: $V_{CCI}$ In $I_{IH}$ of the <i>Electrical Characteristics, 5 V</i> table .....	8
• Changed From: $V_{CCX}$ To: $V_{CCI}$ In CMTI of the <i>Electrical Characteristics, 5 V</i> table .....	8
• Changed From: $V_{CCX}$ To: $V_{CCI}$ In Supply Current, DC Signal of the <i>Electrical Characteristics, 5 V</i> table .....	8
• Changed Note (1) of the <i>Electrical Characteristics, 5 V</i> table .....	9
• Changed From: $V_{CCX}$ To: $V_{CCO}$ In $V_{OH}$ of the <i>Electrical Characteristics, 3.3 V</i> table .....	9
• Changed From: $V_{CCX}$ To: $V_{CCO}$ In $V_{I(HYS)}$ of the <i>Electrical Characteristics, 3.3 V</i> table .....	9
• Changed From: $V_{CCX}$ To: $V_{CCI}$ In $I_{IH}$ of the <i>Electrical Characteristics, 3.3 V</i> table .....	9
• Changed From: $V_{CCX}$ To: $V_{CCI}$ In CMTI of the <i>Electrical Characteristics, 3.3 V</i> table .....	9
• Changed From: $V_{CCX}$ To: $V_{CCI}$ In Supply Current, DC Signal of the <i>Electrical Characteristics, 3.3 V</i> table .....	9
• Changed Note (1) of the <i>Electrical Characteristics, 3.3 V</i> table .....	10
• Changed From: $V_{CCX}$ To: $V_{CCO}$ In $V_{OH}$ of the <i>Electrical Characteristics, 2.5 V</i> table .....	10
• Changed From: $V_{CCX}$ To: $V_{CCI}$ In $I_{IH}$ of the <i>Electrical Characteristics, 2.5 V</i> table .....	10
• Changed From: $V_{CCX}$ To: $V_{CCI}$ In Supply Current, DC Signal of the <i>Electrical Characteristics, 2.5 V</i> table .....	10
• Changed Note (1) of the <i>Electrical Characteristics, 2.5 V</i> table .....	11
• Changed <i>Figure 7</i> .....	14
• Changed From: $V_{CC1}$ To: $V_{CCI}$ in <i>Figure 9</i> .....	15
• Changed <i>Figure 10</i> .....	15
• Changed the Test Condition of CTI in <i>Table 1</i> .....	17
• Changed the MIN value of CTI From" > 600 V To: 600 V .....	17
• Changed <i>Table 2</i> title From: <i>DIN V VDE 0884-10 (VDE V 0884-10) and UL 1577 Insulation Characteristics</i> To: <i>Added the DWW package to</i> .....	18
• Changed <i>Table 2</i> .....	18
• Changed columns VDE and CSA to <i>Table 4</i> .....	19
• Changed title From: <i>IEC Safety Limiting Values</i> To: <i>Safety Limiting Values</i> .....	20
• Changed the table in <i>Safety Limiting Values</i> , added $I_S$ DW-16 package options .....	20
• Changed <i>Figure 13</i> .....	20
• Deleted INPUT-SIDE and OUTPUT-SIDE from columns 1 and 2 of <i>Table 6</i> .....	21
• Changed Note (1) of <i>Table 6</i> .....	21
• Changed the <i>Application Information</i> section .....	23
• Changed the <i>Typical Application</i> section and <i>Figure 16</i> .....	23
• Added text and <i>Figure 17</i> to the <i>Detailed Design Procedure</i> section .....	24

---

**Changes from Original (November 2014) to Revision A****Page**

- 
- Changed From: A product preview that included only page 1 and the pinout section To: A complete data sheet ..... 1
  - Added Note: "This coupler..." to the [High Voltage Feature Description](#) section ..... 17
-

## 5 Pin Configuration and Functions

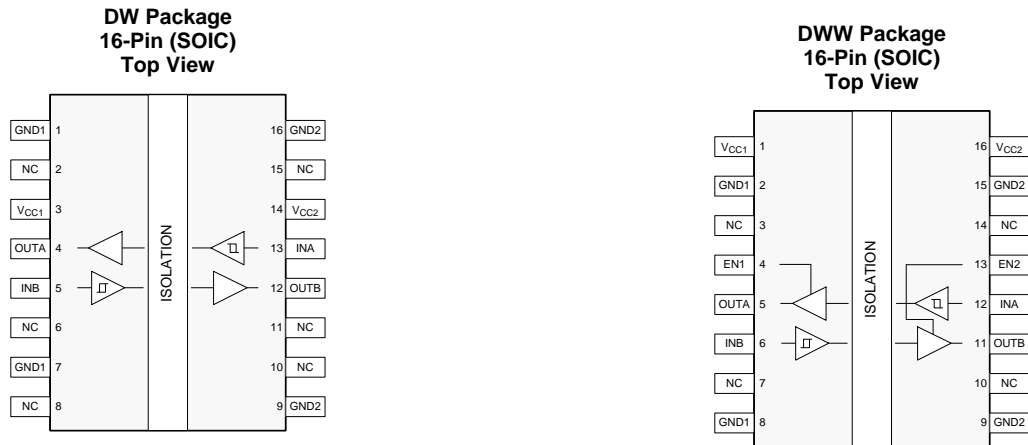

### Pin Functions

NAME	PIN		I/O	DESCRIPTION
	NO. DW	NO. DWW		
GND1	1, 7	2,8	–	Ground connection for $V_{CC1}$
GND2	9, 16	9,15	–	Ground connection for $V_{CC2}$
INA	13	12	I	Input, channel A
INB	5	6	I	Input, channel B
NC	2, 6, 8, 10, 11, 15	3,7,10,14	–	Not connected
OUTA	4	5	O	Output, channel A
OUTB	12	11	O	Output, channel B
$V_{CC1}$	3	1	–	Power supply, $V_{CC1}$
$V_{CC2}$	14	16	–	Power supply, $V_{CC2}$
EN1	–	4	I	Output enable 1. Output pins on side 1 are enabled when EN1 is high or open and in high-impedance state when EN1 is low.
EN2	–	13	I	Output enable 2. Output pins on side 2 are enabled when EN2 is high or open and in high-impedance state when EN2 is low.

## 6 Specifications

### 6.1 Absolute Maximum Ratings<sup>(1)</sup>

		MIN	MAX	UNIT
Supply voltage <sup>(2)</sup>	$V_{CC1}, V_{CC2}$	-0.5	6	V
Voltage	INx, OUTx	-0.5	$V_{CC} + 0.5^{(3)}$	V
Output Current	$I_O$	-15	15	mA
Surge Immunity			12.8	kV
Storage temperature, $T_{stg}$		-65	150	°C

- (1) Stresses beyond those listed under *absolute maximum ratings* may cause permanent damage to the device. These are stress ratings only and functional operation of the device at these or any other conditions beyond those indicated under *Recommended Operating Conditions* is not implied. Exposure to absolute-maximum-rated conditions for extended periods may affect device reliability.
- (2) All voltage values except differential I/O bus voltages are with respect to the local ground terminal (GND1 or GND2) and are peak voltage values.
- (3) Maximum voltage must not exceed 6 V.

### 6.2 ESD Ratings

		VALUE	UNIT	
$V_{ESD}$	Electrostatic discharge	Human body model (HBM), per ANSI/ESDA/JEDEC JS-001, all pins <sup>(1)</sup>	±6000	V
		Charged device model (CDM), per JEDEC specification JESD22-C101, all pins <sup>(2)</sup>	±1500	V

- (1) JEDEC document JEP155 states that 500-V HBM allows safe manufacturing with a standard ESD control process.
- (2) JEDEC document JEP157 states that 250-V CDM allows safe manufacturing with a standard ESD control process.

### 6.3 Recommended Operating Conditions

		MIN	TYP	MAX	UNIT
$V_{CC1}, V_{CC2}$	Supply voltage	2.25		5.5	V
$I_{OH}$	High-level output current	$V_{CCO}^{(1)} = 5\text{ V}$		-4	mA
		$V_{CCO} = 3.3\text{ V}$		-2	
		$V_{CCO} = 2.5\text{ V}$		-1	
$I_{OL}$	Low-level output current	$V_{CCO} = 5\text{ V}$		4	mA
		$V_{CCO} = 3.3\text{ V}$		2	
		$V_{CCO} = 2.5\text{ V}$		1	
$V_{IH}$	High-level input voltage	$0.7 \times V_{CCI}^{(1)}$		$V_{CCI}$	V
$V_{IL}$	Low-level input voltage	0		$0.3 \times V_{CCI}$	V
DR	Signaling rate	0		100	Mbps
$T_J$	Junction temperature <sup>(2)</sup>	-55		150	°C
$T_A$	Ambient temperature	-55	25	125	°C

- (1)  $V_{CCI}$  = Input-side  $V_{CC}$ ;  $V_{CCO}$  = Output-side  $V_{CC}$ .
- (2) To maintain the recommended operating conditions for  $T_J$ , see the [Thermal Information](#) table.

## 6.4 Thermal Information

THERMAL METRIC <sup>(1)</sup>		ISO7821		UNIT
		DW (SOIC)	DWW (SOIC)	
		16 PINS	16-PINS	
$R_{\theta JA}$	Junction-to-ambient thermal resistance	84.7	84.7	°C/W
$R_{\theta JC(top)}$	Junction-to-case(top) thermal resistance	47.3	46.0	°C/W
$R_{\theta JB}$	Junction-to-board thermal resistance	49.4	54.5	°C/W
$\Psi_{JT}$	Junction-to-top characterization parameter	19.1	18.5	°C/W
$\Psi_{JB}$	Junction-to-board characterization parameter	48.8	53.8	°C/W
$R_{\theta JC(bottom)}$	Junction-to-case(bottom) thermal resistance	n/a	n/a	°C/W

(1) For more information about traditional and new thermal metrics, see the [Semiconductor and IC Package Thermal Metrics](#) application report.

## 6.5 Power Dissipation Characteristics

		VALUE	UNIT
$P_D$	Maximum power dissipation by ISO7821x	100	mW
$P_{D1}$	Maximum power dissipation by side-1 of ISO7821x	50	
$P_{D2}$	Maximum power dissipation by side-2 of ISO7821x	50	

$V_{CC1} = V_{CC2} = 5.5\text{ V}$ ,  $T_J = 150^\circ\text{C}$ ,  
 $C_L = 15\text{ pF}$ , input a 50 MHz 50% duty cycle square wave

## 6.6 Electrical Characteristics, 5 V

 $V_{CC1} = V_{CC2} = 5\text{ V} \pm 10\%$  (over recommended operating conditions unless otherwise noted)

PARAMETER		TEST CONDITIONS	MIN	TYP	MAX	UNIT
$V_{OH}$	High-level output voltage	$I_{OH} = -4\text{ mA}$ ; see <a href="#">Figure 7</a>	$V_{CCO}^{(1)} - 0.4$	$V_{CCO} - 0.2$		V
$V_{OL}$	Low-level output voltage	$I_{OL} = 4\text{ mA}$ ; see <a href="#">Figure 7</a>		0.2	0.4	V
$V_{I(HYS)}$	Input threshold voltage hysteresis		$0.1 \times V_{CCO}^{(1)}$			V
$I_{IH}$	High-level input current	$V_{IH} = V_{CCI}^{(1)}$ at INx or ENx			10	μA
$I_{IL}$	Low-level input current	$V_{IL} = 0\text{ V}$ at INx or ENx	-10			
CMTI	Common-mode transient immunity	$V_I = V_{CCI}$ or 0 V; see <a href="#">Figure 10</a>	100			kV/μs
<b>Supply Current - ISO7821DW and ISO7821FDW</b>						
$I_{CC1}, I_{CC2}$	DC Signal	$V_I = 0\text{ V}$ (ISO7821F), $V_I = V_{CCI}^{(1)}$ (ISO7821)		1.2	1.7	mA
$I_{CC1}, I_{CC2}$	DC Signal	$V_I = V_{CCI}^{(1)}$ (ISO7821F), $V_I = 0\text{ V}$ (ISO7821)		2.4	3.4	mA
$I_{CC1}, I_{CC2}$	1 Mbps	All channels switching with square wave clock input; $C_L = 15\text{ pF}$		1.8	2.6	mA
$I_{CC1}, I_{CC2}$	10 Mbps			2.4	3.2	mA
$I_{CC1}, I_{CC2}$	100 Mbps			7.5	9.3	mA
<b>Supply Current - ISO7821DWW and ISO7821FDWW</b>						
$I_{CC1}, I_{CC2}$	Disable	$EN1 = EN2 = 0\text{ V}$ , $V_I = 0\text{ V}$ (ISO7821F), $V_I = V_{CCI}^{(1)}$ (ISO7821)		0.7	1.1	mA
$I_{CC1}, I_{CC2}$	Disable	$EN1 = EN2 = 0\text{ V}$ , $V_I = V_{CCI}^{(1)}$ (ISO7821F), $V_I = 0\text{ V}$ (ISO7821)		1.8	2.9	mA
$I_{CC1}, I_{CC2}$	DC Signal	$V_I = 0\text{ V}$ (ISO7821F), $V_I = V_{CCI}^{(1)}$ (ISO7821)		1.2	1.7	mA
$I_{CC1}, I_{CC2}$	DC Signal	$V_I = V_{CCI}^{(1)}$ (ISO7821F), $V_I = 0\text{ V}$ (ISO7821)		2.4	3.5	mA
$I_{CC1}, I_{CC2}$	1 Mbps	All channels switching with square wave clock input; $C_L = 15\text{ pF}$		1.9	2.7	mA
$I_{CC1}, I_{CC2}$	10 Mbps			2.5	3.2	mA
$I_{CC1}, I_{CC2}$	100 Mbps			7.7	9.3	mA

(1)  $V_{CCI}$  = Input-side  $V_{CC}$ ;  $V_{CCO}$  = Output-side  $V_{CC}$ .

## 6.7 Electrical Characteristics, 3.3 V

 $V_{CC1} = V_{CC2} = 3.3 \text{ V} \pm 10\%$  (over recommended operating conditions unless otherwise noted)

PARAMETER		TEST CONDITIONS	MIN	TYP	MAX	UNIT
$V_{OH}$	High-level output voltage	$I_{OH} = -2 \text{ mA}$ ; see <a href="#">Figure 7</a>	$V_{CCO}^{(1)} - 0.4$	$V_{CCO} - 0.2$		V
$V_{OL}$	Low-level output voltage	$I_{OL} = 2 \text{ mA}$ ; see <a href="#">Figure 7</a>		0.2	0.4	V
$V_{I(HYS)}$	Input threshold voltage hysteresis		$0.1 \times V_{CCO}$			V
$I_{IH}$	High-level input current	$V_{IH} = V_{CCI}^{(1)}$ at INx or ENx			10	μA
$I_{IL}$	Low-level input current	$V_{IL} = 0 \text{ V}$ at INx or ENx	-10			
CMTI	Common-mode transient immunity	$V_I = V_{CCI}$ or $0 \text{ V}$ ; see <a href="#">Figure 10</a>	100			kV/μs
<b>Supply Current - ISO7821DW and ISO7821FDW</b>						
$I_{CC1}, I_{CC2}$	DC Signal	$V_I = 0 \text{ V}$ (ISO7821F), $V_I = V_{CCI}^{(1)}$ (ISO7821)		1.2	1.7	mA
$I_{CC1}, I_{CC2}$	DC Signal	$V_I = V_{CCI}^{(1)}$ (ISO7821F), $V_I = 0 \text{ V}$ (ISO7821)		2.4	3.4	mA
$I_{CC1}, I_{CC2}$	1 Mbps	All channels switching with square wave clock input; $C_L = 15 \text{ pF}$		1.8	2.6	mA
$I_{CC1}, I_{CC2}$	10 Mbps			2.2	3	mA
$I_{CC1}, I_{CC2}$	100 Mbps			5.8	7.1	mA
<b>Supply Current - ISO7821DWW and ISO7821FDWW</b>						
$I_{CC1}, I_{CC2}$	Disable	$EN1 = EN2 = 0 \text{ V}$ , $V_I = 0 \text{ V}$ (ISO7821F), $V_I = V_{CCI}^{(1)}$ (ISO7821)		0.7	1.1	mA
$I_{CC1}, I_{CC2}$	Disable	$EN1 = EN2 = 0 \text{ V}$ , $V_I = V_{CCI}^{(1)}$ (ISO7821F), $V_I = 0 \text{ V}$ (ISO7821)		1.8	2.9	mA
$I_{CC1}, I_{CC2}$	DC Signal	$V_I = 0 \text{ V}$ (ISO7821F), $V_I = V_{CCI}^{(1)}$ (ISO7821)		1.2	1.7	mA
$I_{CC1}, I_{CC2}$	DC Signal	$V_I = V_{CCI}^{(1)}$ (ISO7821F), $V_I = 0 \text{ V}$ (ISO7821)		2.4	3.5	mA
$I_{CC1}, I_{CC2}$	1 Mbps	All channels switching with square wave clock input; $C_L = 15 \text{ pF}$		1.9	2.6	mA
$I_{CC1}, I_{CC2}$	10 Mbps			2.3	3	mA
$I_{CC1}, I_{CC2}$	100 Mbps			5.9	7.1	mA

 (1)  $V_{CCI}$  = Input-side  $V_{CC}$ ;  $V_{CCO}$  = Output-side  $V_{CC}$ .

## 6.8 Electrical Characteristics, 2.5 V

 $V_{CC1} = V_{CC2} = 2.5 \text{ V} \pm 10\%$  (over recommended operating conditions unless otherwise noted)

PARAMETER		TEST CONDITIONS	MIN	TYP	MAX	UNIT
$V_{OH}$	High-level output voltage	$I_{OH} = -1 \text{ mA}$ ; see <a href="#">Figure 7</a>	$V_{CCO}^{(1)} - 0.4$	$V_{CCO} - 0.2$		V
$V_{OL}$	Low-level output voltage	$I_{OL} = 1 \text{ mA}$ ; see <a href="#">Figure 7</a>		0.2	0.4	V
$V_{I(HYS)}$	Input threshold voltage hysteresis		$0.1 \times V_{CCO}$			V
$I_{IH}$	High-level input current	$V_{IH} = V_{CCI}^{(1)}$ at INx or ENx			10	μA
$I_{IL}$	Low-level input current	$V_{IL} = 0 \text{ V}$ at INx or ENx	-10			
CMTI	Common-mode transient immunity	$V_I = V_{CCI}$ or 0 V; see <a href="#">Figure 10</a>	100			kV/μs
<b>Supply Current - ISO7821DW and ISO7821FDW</b>						
$I_{CC1}, I_{CC2}$	DC Signal	$V_I = 0 \text{ V}$ (ISO7821F), $V_I = V_{CCI}^{(1)}$ (ISO7821)		1.2	1.7	mA
$I_{CC1}, I_{CC2}$	DC Signal	$V_I = V_{CCI}^{(1)}$ (ISO7821F), $V_I = 0 \text{ V}$ (ISO7821)		2.4	3.4	mA
$I_{CC1}, I_{CC2}$	1 Mbps	All channels switching with square wave clock input; $C_L = 15 \text{ pF}$		1.8	2.6	mA
$I_{CC1}, I_{CC2}$	10 Mbps			2.1	2.8	mA
$I_{CC1}, I_{CC2}$	100 Mbps			4.9	5.9	mA
<b>Supply Current - ISO7821DWW and ISO7821FDWW</b>						
$I_{CC1}, I_{CC2}$	Disable	$EN1 = EN2 = 0 \text{ V}$ , $V_I = 0 \text{ V}$ (ISO7821F), $V_I = V_{CCI}^{(1)}$ (ISO7821)		0.7	1.1	mA
$I_{CC1}, I_{CC2}$	Disable	$EN1 = EN2 = 0 \text{ V}$ , $V_I = V_{CCI}^{(1)}$ (ISO7821F), $V_I = 0 \text{ V}$ (ISO7821)		1.8	2.9	mA
$I_{CC1}, I_{CC2}$	DC Signal	$V_I = 0 \text{ V}$ (ISO7821F), $V_I = V_{CCI}^{(1)}$ (ISO7821)		1.2	1.7	mA
$I_{CC1}, I_{CC2}$	DC Signal	$V_I = V_{CCI}^{(1)}$ (ISO7821F), $V_I = 0 \text{ V}$ (ISO7821)		2.4	3.5	mA
$I_{CC1}, I_{CC2}$	1 Mbps	All channels switching with square wave clock input; $C_L = 15 \text{ pF}$		1.9	2.6	mA
$I_{CC1}, I_{CC2}$	10 Mbps			2.2	2.9	mA
$I_{CC1}, I_{CC2}$	100 Mbps			5	6	mA

(1)  $V_{CCI}$  = Input-side  $V_{CC}$ ;  $V_{CCO}$  = Output-side  $V_{CC}$ .

## 6.9 Switching Characteristics, 5 V

 $V_{CC1} = V_{CC2} = 5\text{ V} \pm 10\%$  (over recommended operating conditions unless otherwise noted)

PARAMETER		TEST CONDITIONS	MIN	TYP	MAX	UNIT
$t_{PLH}$ , $t_{PHL}$	Propagation delay time	See <a href="#">Figure 7</a>	6	10.7	16	ns
PWD <sup>(1)</sup>	Pulse width distortion $ t_{PHL} - t_{PLH} $					
$t_{sk(pp)}$ <sup>(2)</sup>	Part-to-part skew time				4.5	ns
$t_r$	Output signal rise time	See <a href="#">Figure 7</a>		2.4	3.9	ns
$t_f$	Output signal fall time					
$t_{PHZ}$	Disable propagation delay, high-to-high impedance output for ISO7821DWW and ISO7821FDWW	See <a href="#">Figure 8</a>		12	20	ns
$t_{PLZ}$	Disable propagation delay, low-to-high impedance output for ISO7821DWW and ISO7821FDWW					
$t_{PZH}$	Enable propagation delay, high impedance-to-high output for ISO7821DWW					
	Enable propagation delay, high impedance-to-high output for ISO7821FDWW					
$t_{PZL}$	Enable propagation delay, high impedance-to-low output for ISO7821DWW					
	Enable propagation delay, high impedance-to-low output for ISO7821FDWW					
$t_{is}$	Default output delay time from input power loss	Measured from the time $V_{CC}$ goes below 1.7 V. See <a href="#">Figure 9</a>		0.2	9	$\mu\text{s}$
$t_{ie}$	Time interval error	$2^{16} - 1$ PRBS data at 100 Mbps		1		ns

(1) Also known as Pulse Skew.

(2)  $t_{sk(pp)}$  is the magnitude of the difference in propagation delay times between any terminals of different devices switching in the same direction while operating at identical supply voltages, temperature, input signals and loads.

## 6.10 Switching Characteristics, 3.3 V

 $V_{CC1} = V_{CC2} = 3.3\text{ V} \pm 10\%$  (over recommended operating conditions unless otherwise noted)

PARAMETER		TEST CONDITIONS	MIN	TYP	MAX	UNIT
$t_{PLH}$ , $t_{PHL}$	Propagation delay time	See <a href="#">Figure 7</a>	6	10.8	16	ns
PWD <sup>(1)</sup>	Pulse width distortion $ t_{PHL} - t_{PLH} $					
$t_{sk(pp)}$ <sup>(2)</sup>	Part-to-part skew time				4.5	ns
$t_r$	Output signal rise time	See <a href="#">Figure 7</a>		1.3	3	ns
$t_f$	Output signal fall time					
$t_{PHZ}$	Disable propagation delay, high-to-high impedance output for ISO7821DWW and ISO7821FDWW	See <a href="#">Figure 8</a>		17	32	ns
$t_{PLZ}$	Disable propagation delay, low-to-high impedance output for ISO7821DWW and ISO7821FDWW					
$t_{PZH}$	Enable propagation delay, high impedance-to-high output for ISO7821DWW					
	Enable propagation delay, high impedance-to-high output for ISO7821FDWW					
$t_{PZL}$	Enable propagation delay, high impedance-to-low output for ISO7821DWW					
	Enable propagation delay, high impedance-to-low output for ISO7821FDWW					
$t_{is}$	Default output delay time from input power loss	Measured from the time $V_{CC}$ goes below 1.7 V. See <a href="#">Figure 9</a>		0.2	9	$\mu\text{s}$
$t_{ie}$	Time interval error	$2^{16} - 1$ PRBS data at 100 Mbps		1		ns

(1) Also known as Pulse Skew.

(2)  $t_{sk(pp)}$  is the magnitude of the difference in propagation delay times between any terminals of different devices switching in the same direction while operating at identical supply voltages, temperature, input signals and loads.

## 6.11 Switching Characteristics, 2.5 V

 $V_{CC1} = V_{CC2} = 2.5 \text{ V} \pm 10\%$  (over recommended operating conditions unless otherwise noted)

PARAMETER		TEST CONDITIONS	MIN	TYP	MAX	UNIT	
$t_{PLH}, t_{PHL}$	Propagation delay time	See <a href="#">Figure 7</a>	7.5	11.7	17.5	ns	
PWD <sup>(1)</sup>	Pulse width distortion $ t_{PHL} - t_{PLH} $		0.7	4.7			
$t_{sk(pp)}$ <sup>(2)</sup>	Part-to-part skew time			4.5			
$t_r$	Output signal rise time	See <a href="#">Figure 7</a>		1.8	3.5	ns	
$t_f$	Output signal fall time			1.8	3.5		
$t_{PHZ}$	Disable propagation delay, high-to-high impedance output for ISO7821DWW and ISO7821FDWW	See <a href="#">Figure 8</a>		22	45	ns	
$t_{PLZ}$	Disable propagation delay, low-to-high impedance output for ISO7821DWW and ISO7821FDWW			22	45	ns	
$t_{PZH}$	Enable propagation delay, high impedance-to-high output for ISO7821DWW			18	45	ns	
	Enable propagation delay, high impedance-to-high output for ISO7821FDWW			2	2.5	$\mu\text{s}$	
$t_{PZL}$	Enable propagation delay, high impedance-to-low output for ISO7821DWW			2	2.5	$\mu\text{s}$	
	Enable propagation delay, high impedance-to-low output for ISO7821FDWW			18	45	ns	
$t_{fs}$	Default output delay time from input power loss		Measured from the time $V_{CC}$ goes below 1.7 V. See <a href="#">Figure 9</a>		0.2	9	$\mu\text{s}$
$t_{ie}$	Time interval error		$2^{16} - 1$ PRBS data at 100 Mbps		1		ns

(1) Also known as Pulse Skew.

(2)  $t_{sk(pp)}$  is the magnitude of the difference in propagation delay times between any terminals of different devices switching in the same direction while operating at identical supply voltages, temperature, input signals and loads.

## 6.12 Typical Characteristics

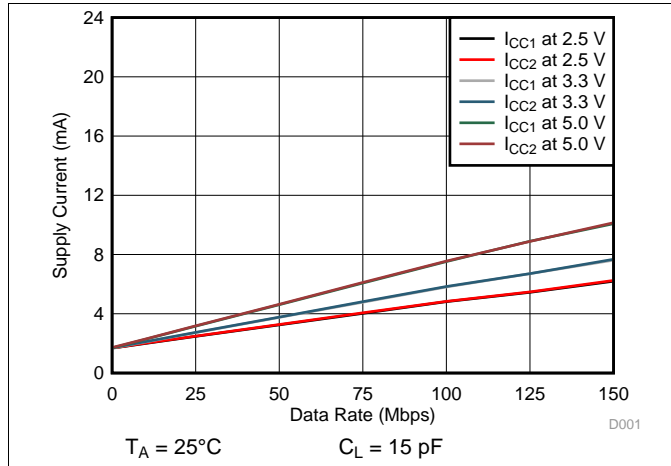

Figure 1. Supply Current vs Data Rate (with 15 pF Load)

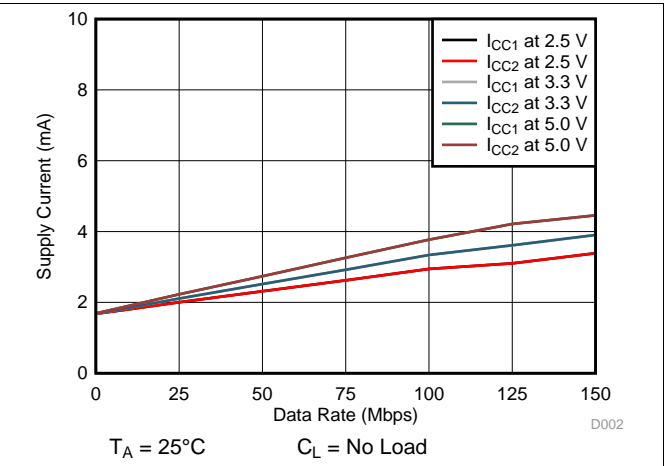

Figure 2. Supply Current vs Data Rate (with No Load)

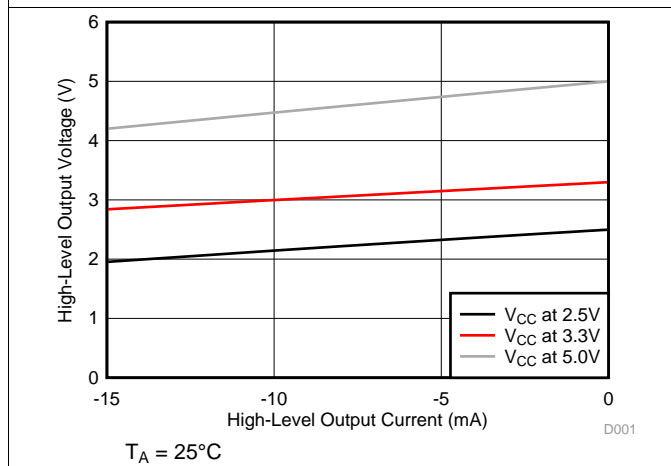

Figure 3. High-Level Output Voltage vs High-level Output Current

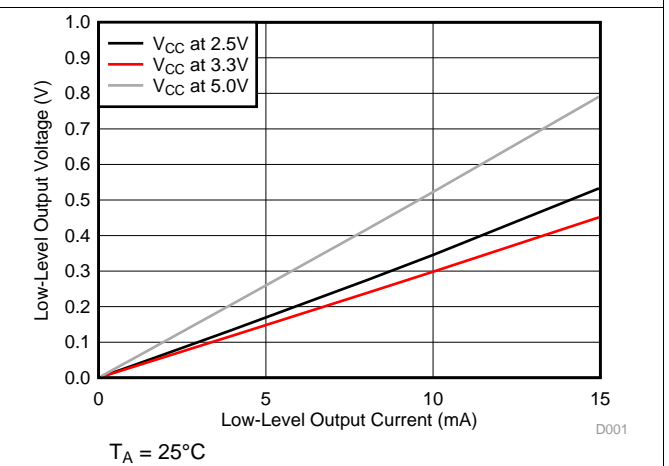

Figure 4. Low-Level Output Voltage vs Low-Level Output Current

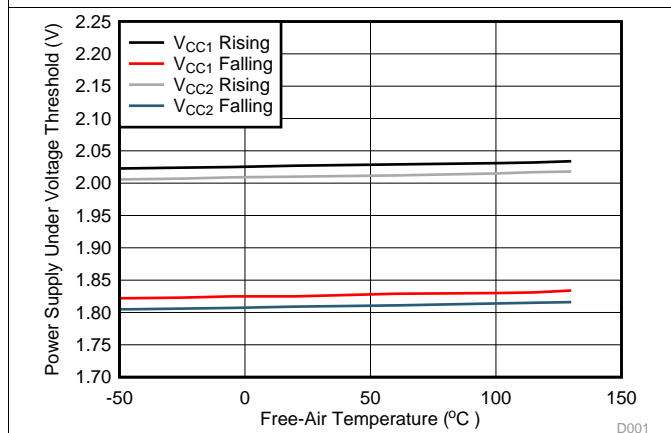

Figure 5. Power Supply Undervoltage Threshold vs Free-Air Temperature

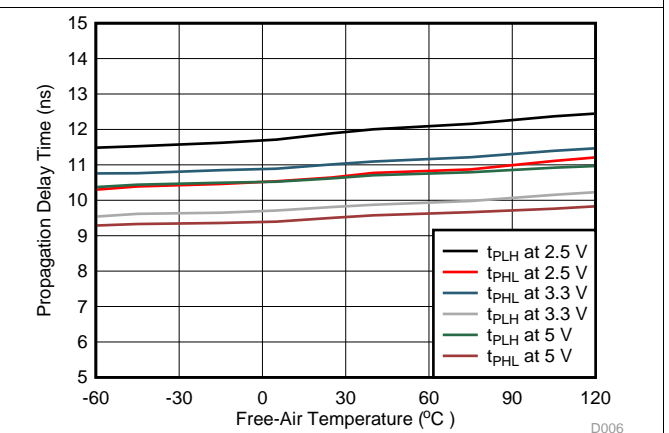
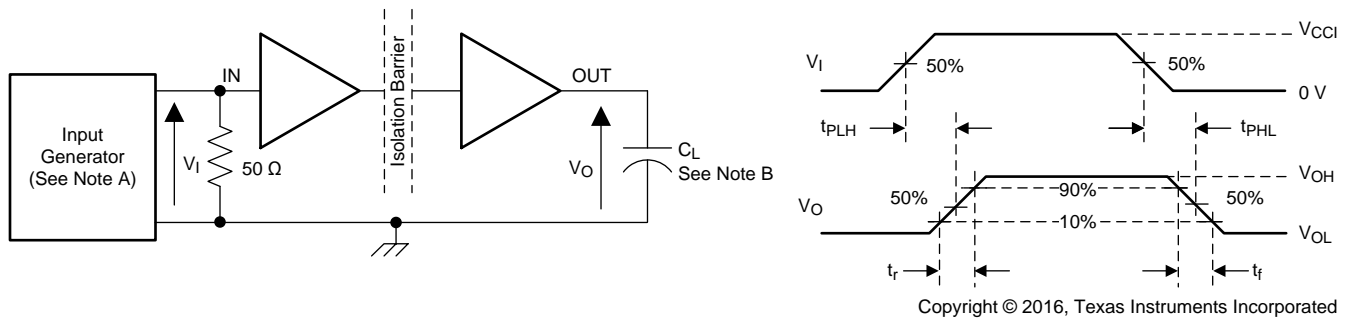

Figure 6. Propagation Delay Time vs Free-Air Temperature

## 7 Parameter Measurement Information



- A. The input pulse is supplied by a generator having the following characteristics: PRR  $\leq$  50 kHz, 50% duty cycle,  $t_r \leq 3$  ns,  $t_f \leq 3$  ns,  $Z_O = 50 \Omega$ . At the input,  $50 \Omega$  resistor is required to terminate Input Generator signal. It is not needed in actual application.
- B.  $C_L = 15$  pF and includes instrumentation and fixture capacitance within  $\pm 20\%$ .

**Figure 7. Switching Characteristics Test Circuit and Voltage Waveforms**

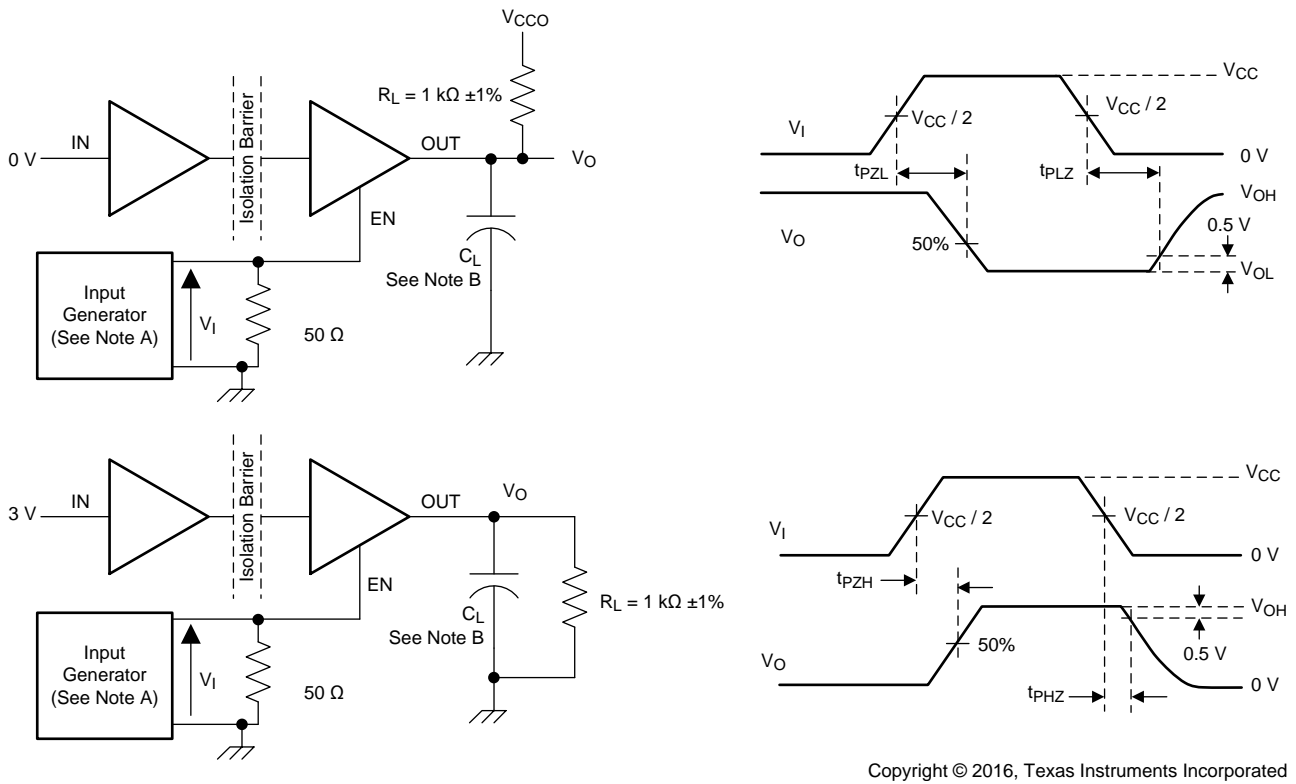

- A. The input pulse is supplied by a generator having the following characteristics: PRR  $\leq$  10 kHz, 50% duty cycle,  $t_r \leq 3$  ns,  $t_f \leq 3$  ns,  $Z_O = 50 \Omega$ .
- B.  $C_L = 15$  pF and includes instrumentation and fixture capacitance within  $\pm 20\%$ .

**Figure 8. Enable/Disable Propagation Delay Time Test Circuit and Waveform**

Parameter Measurement Information (continued)

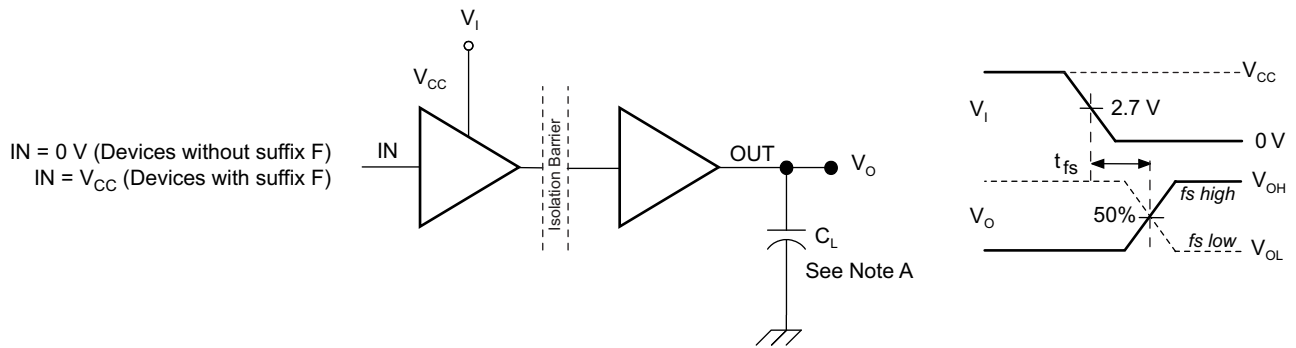

Copyright © 2016, Texas Instruments Incorporated

- A.  $C_L = 15 \text{ pF}$  and includes instrumentation and fixture capacitance within  $\pm 20\%$ .

Figure 9. Default Output Delay Time Test Circuit and Voltage Waveforms

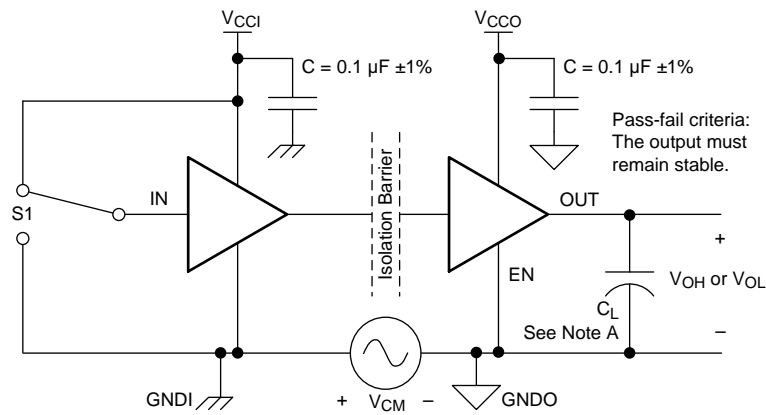

Copyright © 2016, Texas Instruments Incorporated

- A.  $C_L = 15 \text{ pF}$  and includes instrumentation and fixture capacitance within  $\pm 20\%$ .

Figure 10. Common-Mode Transient Immunity Test Circuit

## 8 Detailed Description

### 8.1 Overview

ISO7821 employs an ON-OFF Keying (OOK) modulation scheme to transmit the digital data across a silicon dioxide based isolation barrier. The transmitter sends a high frequency carrier across the barrier to represent one digital state and sends no signal to represent the other digital state. The receiver demodulates the signal after advanced signal conditioning and produces the output through a buffer stage. These devices also incorporate advanced circuit techniques to maximize the CMTI performance and minimize the radiated emissions due to the high frequency carrier and IO buffer switching. The conceptual block diagram of a digital capacitive isolator, [Figure 11](#), shows a functional block diagram of a typical channel.

### 8.2 Functional Block Diagram

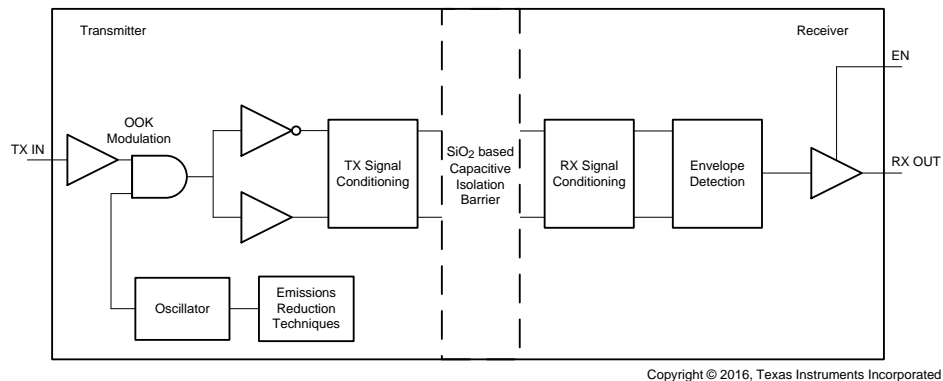

**Figure 11. Conceptual Block Diagram of a Digital Capacitive Isolator**

Also a conceptual detail of how the ON/OFF Keying scheme works is shown in [Figure 12](#).

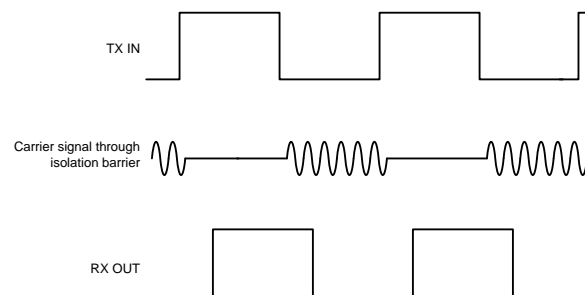

**Figure 12. On-Off Keying (OOK) Based Modulation Scheme**

### 8.3 Feature Description

ISO7821 is available in two channel configurations and default output state options to enable a variety of application uses.

PRODUCT	CHANNEL DIRECTION	RATED ISOLATION	MAX DATA RATE	DEFAULT OUTPUT
ISO7821	1 Forward, 1 Reverse	5700 V <sub>RMS</sub> / 8000 V <sub>PK</sub> <sup>(1)</sup>	100 Mbps	High
ISO7821F	1 Forward, 1 Reverse	5700 V <sub>RMS</sub> / 8000 V <sub>PK</sub> <sup>(1)</sup>	100 Mbps	Low

(1) See the [Regulatory Information](#) section for detailed isolation ratings.

#### 8.3.1 High Voltage Feature Description

#### NOTE

This coupler is suitable for 'safe electrical insulation' only within the safety ratings. Compliance with the safety ratings shall be ensured by means of suitable protective circuits.

**Table 1. Package Insulation and Safety-Related Specifications  
(over recommended operating conditions (unless otherwise noted))**

PARAMETER		TEST CONDITIONS	MIN	TYP	MAX	UNIT
CLR	External clearance	Shortest terminal-to-terminal distance through air	DW-16	8		mm
			DWW-16	14.5		
CPG	External creepage	Shortest terminal-to-terminal distance across the package surface	DW-16	8		mm
			DWW-16	14.5		
CTI	Comparative tracking index	DIN EN 60112 (VDE 0303-11); IEC 60112; UL 746A	600			V
R <sub>IO</sub>	Isolation resistance, input to output <sup>(1)</sup>	V <sub>IO</sub> = 500 V, T <sub>A</sub> = 25°C	10 <sup>12</sup>			Ω
		V <sub>IO</sub> = 500 V, 100°C ≤ T <sub>A</sub> ≤ max	10 <sup>11</sup>			Ω
C <sub>IO</sub>	Barrier capacitance, input to output <sup>(1)</sup>	V <sub>IO</sub> = 0.4 x sin (2πft), f = 1 MHz		1		pF
C <sub>I</sub>	Input capacitance <sup>(2)</sup>	V <sub>I</sub> = V <sub>CC</sub> /2 + 0.4 x sin (2πft), f = 1 MHz, V <sub>CC</sub> = 5 V		2		pF

(1) All pins on each side of the barrier tied together creating a two-terminal device.

(2) Measured from input pin to ground.

#### NOTE

Creepage and clearance requirements should be applied according to the specific equipment isolation standards of an application. Care should be taken to maintain the creepage and clearance distance of a board design to ensure that the mounting pads of the isolator on the printed-circuit board do not reduce this distance.

Creepage and clearance on a printed-circuit board become equal in certain cases. Techniques such as inserting grooves and/or ribs on a printed circuit board are used to help increase these specifications.

**Table 2. Insulation Characteristics**

PARAMETER		TEST CONDITIONS	SPECIFICATION		UNIT
			DW	DWW	
DTI	Distance through the insulation	Minimum internal gap (internal clearance)	21	21	μm
V <sub>IOWM</sub>	Maximum working isolation voltage	Time dependent dielectric breakdown (TDDb) test	1500	2000	V <sub>RMS</sub>
			2121	2828	V <sub>DC</sub>
<b>DIN V VDE V 0884-10 (VDE V 0884-10):2006-12</b>					
V <sub>IOTM</sub>	Maximum transient isolation voltage	V <sub>TEST</sub> = V <sub>IOTM</sub> t = 60 sec (qualification) t = 1 sec (100% production)	8000	8000	V <sub>PK</sub>
V <sub>IOSM</sub>	Maximum surge isolation voltage	Test method per IEC 60065, 1.2/50 μs waveform, V <sub>TEST</sub> = 1.6 x V <sub>IOSM</sub> = 12800 V <sub>PK</sub> <sup>(1)</sup> (qualification)	8000	8000	V <sub>PK</sub>
V <sub>IORM</sub>	Maximum repetitive peak isolation voltage		2121	2828	V <sub>PK</sub>
V <sub>PR</sub>	Input-to-output test voltage	Method a, After Input/Output safety test subgroup 2/3, V <sub>PR</sub> = V <sub>IORM</sub> x 1.2, t = 10 s, Partial discharge < 5 pC	2545	3394	V <sub>PK</sub>
		Method a, After environmental tests subgroup 1, V <sub>PR</sub> = V <sub>IORM</sub> x 1.6, t = 10 s, Partial Discharge < 5 pC	3394	4525	
		Method b1, After environmental tests subgroup 1, V <sub>PR</sub> = V <sub>IORM</sub> x 1.875, t = 1 s (100% Production test) Partial discharge < 5 pC	3977	5303	
R <sub>S</sub>	Isolation resistance	V <sub>IO</sub> = 500 V at T <sub>S</sub>	>10 <sup>9</sup>	>10 <sup>9</sup>	Ω
	Pollution degree		2	2	
	Climatic category		55/125/21	55/125/21	
<b>UL 1577</b>					
V <sub>ISO</sub>	Withstanding isolation voltage	V <sub>TEST</sub> = V <sub>ISO</sub> = 5700 V <sub>RMS</sub> , t = 60 sec (qualification); V <sub>TEST</sub> = 1.2 x V <sub>ISO</sub> = 6840 V <sub>RMS</sub> , t = 1 sec (100% production)	5700	5700	V <sub>RMS</sub>

(1) Testing is carried out in air or oil to determine the intrinsic surge immunity of the isolation barrier.

**Table 3. IEC 60664-1 Ratings Table**

PARAMETER		TEST CONDITIONS	SPECIFICATION
Material group			I
Overvoltage category / Installation classification	DW package	Rated mains voltage ≤ 600 V <sub>RMS</sub>	I–IV
		Rated mains voltage ≤ 1000 V <sub>RMS</sub>	I–III
	DWW package	Rated mains voltage ≤ 1000 V <sub>RMS</sub>	I–IV

### 8.3.1.1 Regulatory Information

DW package certifications are complete; DWW package certifications completed for UL and TUV and planned for VDE, CSA, and CQC.

**Table 4. Regulatory Information**

VDE	CSA	UL	CQC	TUV
Certified according to DIN V VDE V 0884-10 (VDE V 0884-10):2006-12 and DIN EN 60950-1 (VDE 0805 Teil 1):2011-01	Approved under CSA Component Acceptance Notice 5A, IEC 60950-1 and IEC 60601-1	Recognized under UL 1577 Component Recognition Program	Certified according to GB 4943.1-2011	Certified according to EN 61010-1:2010 (3rd Ed) and EN 60950-1:2006/A11:2009/A1:2010/A12:2011/A2:2013
Reinforced insulation Maximum transient isolation voltage, 8000 V <sub>PK</sub> ; Maximum repetitive peak isolation voltage, 2121 V <sub>PK</sub> (DW), 2828 V <sub>PK</sub> (DWW); Maximum surge isolation voltage, 8000 V <sub>PK</sub>	Reinforced insulation per CSA 60950-1-07+A1+A2 and IEC 60950-1 2nd Ed., 800 V <sub>RMS</sub> (DW package) and 1450 V <sub>RMS</sub> (DWW package) max working voltage (pollution degree 2, material group I); 2 MOPP (Means of Patient Protection) per CSA 60601-1:14 and IEC 60601-1 Ed. 3.1, 250 V <sub>RMS</sub> (354 V <sub>PK</sub> ) max working voltage (DW package)	Single protection, 5700 V <sub>RMS</sub>	Reinforced Insulation, Altitude ≤ 5000 m, Tropical Climate, 250 V <sub>RMS</sub> maximum working voltage	5700 V <sub>RMS</sub> Reinforced insulation per EN 61010-1:2010 (3rd Ed) up to working voltage of 600 V <sub>RMS</sub> (DW package) and 1000 V <sub>RMS</sub> (DWW package)  5700 V <sub>RMS</sub> Reinforced insulation per EN 60950-1:2006/A11:2009/A1:2010/A12:2011/A2:2013 up to working voltage of 800 V <sub>RMS</sub> (DW package) and 1450 V <sub>RMS</sub> (DWW package)
Certificate number: 40040142	Master contract number: 220991	File number: E181974	Certificate number: CQC15001121716	Client ID number: 77311

**8.3.1.2 Safety Limiting Values**

Safety limiting intends to prevent potential damage to the isolation barrier upon failure of input or output circuitry. A failure of the I/O can allow low resistance to ground or the supply and, without current limiting, dissipate sufficient power to overheat the die and damage the isolation barrier potentially leading to secondary system failures.

**Table 5. Safety Limiting**

PARAMETER	TEST CONDITIONS	MIN	TYP	MAX	UNIT
I <sub>S</sub>	R <sub>θJA</sub> = 84.7°C/W, V <sub>I</sub> = 5.5 V, T <sub>J</sub> = 150°C, T <sub>A</sub> = 25°C			268	mA
	R <sub>θJA</sub> = 84.7°C/W, V <sub>I</sub> = 3.6 V, T <sub>J</sub> = 150°C, T <sub>A</sub> = 25°C			410	
	R <sub>θJA</sub> = 84.7°C/W, V <sub>I</sub> = 2.75 V, T <sub>J</sub> = 150°C, T <sub>A</sub> = 25°C			537	
P <sub>S</sub>	R <sub>θJA</sub> = 84.7°C/W, T <sub>J</sub> = 150°C, T <sub>A</sub> = 25°C			1476	mW
T <sub>S</sub>				150	°C

The maximum safety temperature is the maximum junction temperature specified for the device. The power dissipation and junction-to-air thermal impedance of the device installed in the application hardware determines the junction temperature. The assumed junction-to-air thermal resistance in the [Thermal Information](#) is that of a device installed on a High-K test board for Leaded Surface Mount Packages. The power is the recommended maximum input voltage times the current. The junction temperature is then the ambient temperature plus the power times the junction-to-air thermal resistance.

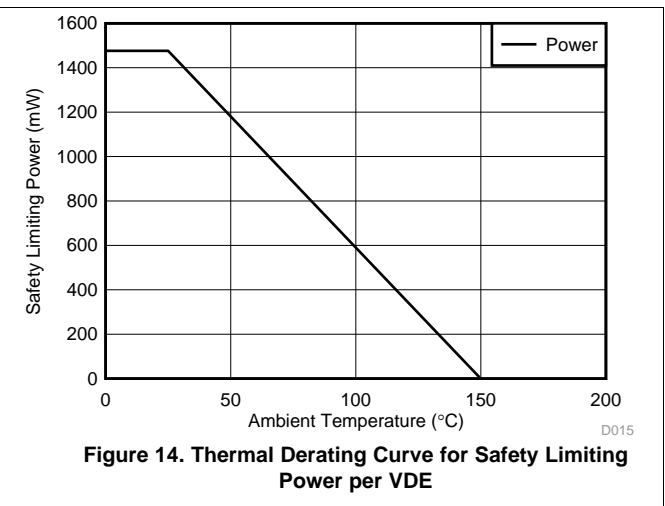
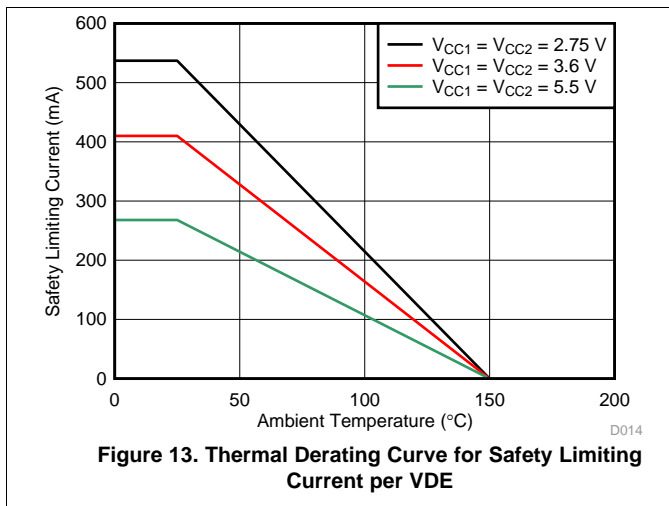

## 8.4 Device Functional Modes

ISO7821 functional modes are shown in [Table 6](#).

**Table 6. ISO7821 Function Table<sup>(1)</sup>**

$V_{CCI}$	$V_{CCO}$	INPUT (INx) <sup>(2)</sup>	OUTPUT ENABLE (ENx) (DWW Package Only)	OUTPUT (OUTx)	COMMENTS
PU	PU	H	H or open	H	Normal Operation: A channel output assumes the logic state of its input.
		L	H or open	L	
		Open	H or open	Default	Default mode: When INx is open, the corresponding channel output goes to its default high logic state. Default= High for ISO7821 and Low for ISO7821F.
X	PU	X	L	Z	A low value of Output Enable causes the outputs to be high-impedance.
PD	PU	X	H or open	Default	Default mode: When $V_{CCI}$ is unpowered, a channel output assumes the logic state based on the selected default option. Default= High for ISO7821 and Low for ISO7821F. When $V_{CCI}$ transitions from unpowered to powered-up, a channel output assumes the logic state of its input. When $V_{CCI}$ transitions from powered-up to unpowered, channel output assumes the selected default state.
X	PD	X	X	Undetermined	When $V_{CCO}$ is unpowered, a channel output is undetermined <sup>(3)</sup> . When $V_{CCO}$ transitions from unpowered to powered-up, a channel output assumes the logic state of its input

- (1)  $V_{CCI}$  = Input-side  $V_{CC}$ ;  $V_{CCO}$  = Output-side  $V_{CC}$ ; PU = Powered up ( $V_{CC} \geq 2.25$  V); PD = Powered down ( $V_{CC} \leq 1.7$  V); X = Irrelevant; H = High level; L = Low level; Z = High impedance
- (2) A strongly driven input signal can weakly power the floating  $V_{CC}$  via an internal protection diode and cause undetermined output.
- (3) The outputs are in undetermined state when  $1.7$  V <  $V_{CCI}$ ,  $V_{CCO}$  < 2.25 V.

8.4.1 Device I/O Schematics

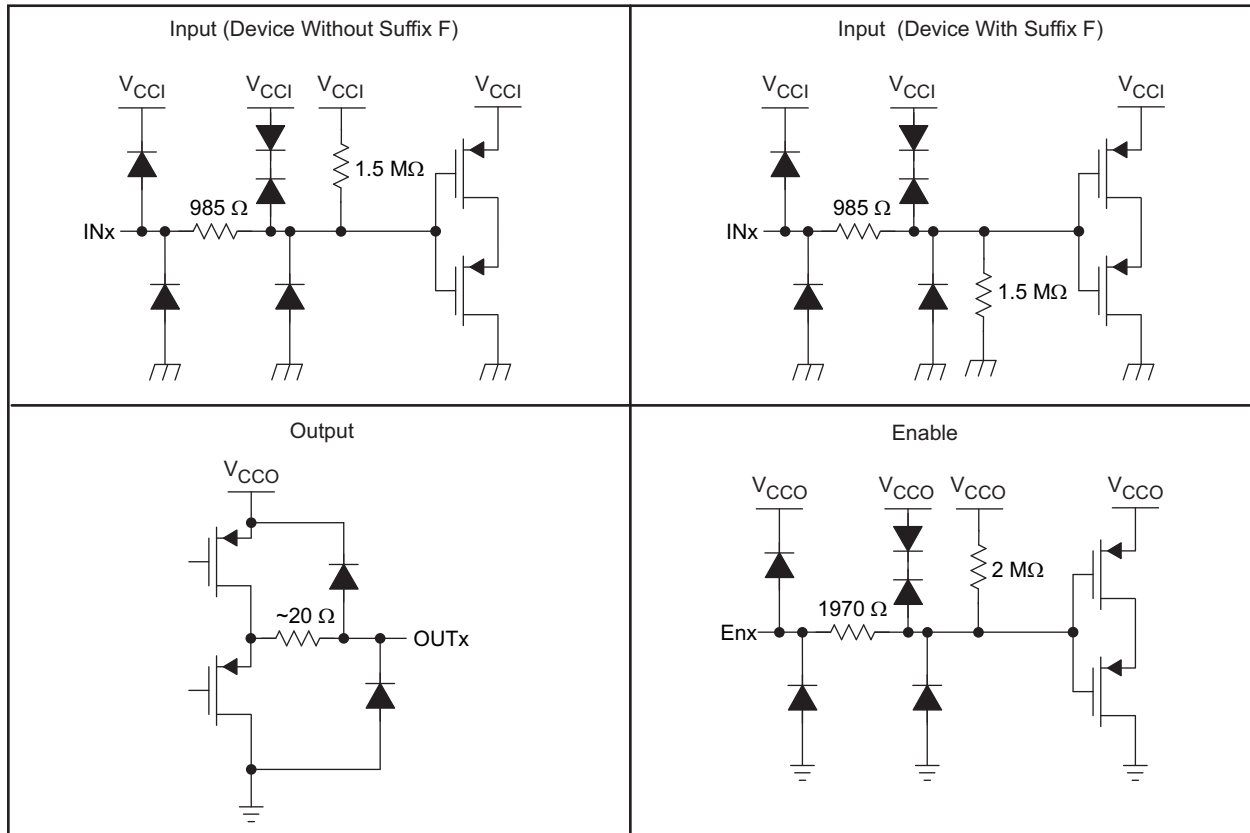

Copyright © 2016, Texas Instruments Incorporated

Figure 15. Device I/O Schematics

## 9 Application and Implementation

### NOTE

Information in the following applications sections is not part of the TI component specification, and TI does not warrant its accuracy or completeness. TI's customers are responsible for determining suitability of components for their purposes. Customers should validate and test their design implementation to confirm system functionality.

### 9.1 Application Information

The ISO7821 is a high-performance, dual-channel digital isolator with 5.7 kV<sub>RMS</sub> isolation voltage per UL 1577. It utilizes single-ended CMOS-logic switching technology. Its supply voltage range is from 2.25 V to 5.5 V for both supplies, V<sub>CC1</sub> and V<sub>CC2</sub>. When designing with digital isolators, it is important to keep in mind that due to the single-ended design structure, digital isolators do not conform to any specific interface standard and are only intended for isolating single-ended CMOS or TTL digital signal lines. The isolator is typically placed between the data controller (that is,  $\mu$ C or UART), and a data converter or a line transceiver, regardless of the interface type or standard.

### 9.2 Typical Application

ISO7821 can be used with Texas Instruments' mixed signal micro-controller, digital-to-analog converter, transformer driver, and voltage regulator to create an isolated 4-20 mA current loop.

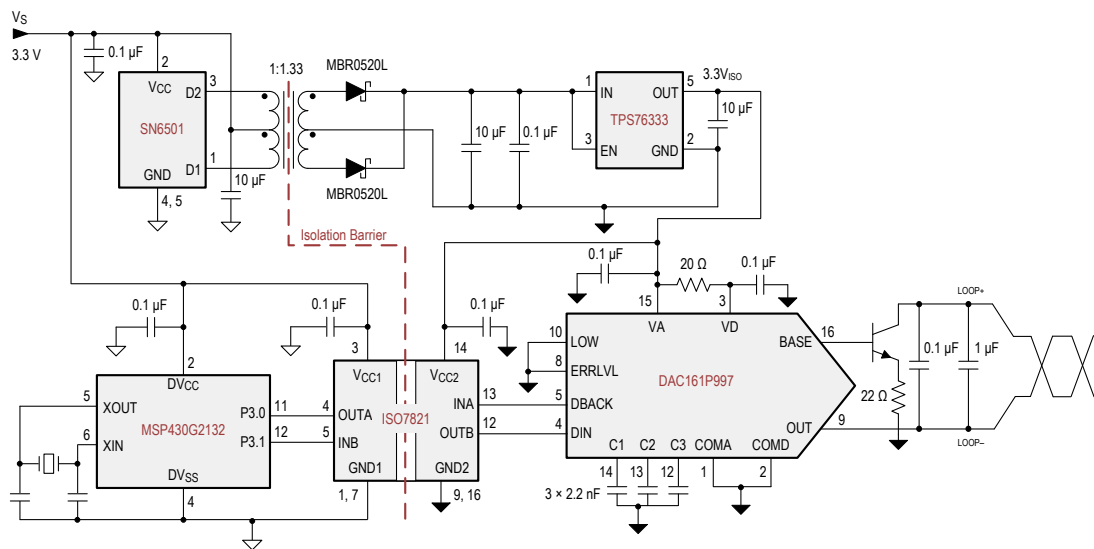

Figure 16. Isolated 4-20 mA Current Loop

#### 9.2.1 Design Requirements

For the ISO7821, use the parameters shown in [Table 7](#).

Table 7. Design Parameters

PARAMETER	VALUE
Supply voltage	2.25 V to 5.5 V
Decoupling capacitor between V <sub>CC1</sub> and GND1	0.1 $\mu$ F
Decoupling capacitor from V <sub>CC2</sub> and GND2	0.1 $\mu$ F

## 9.2.2 Detailed Design Procedure

Unlike optocouplers, which need external components to improve performance, provide bias, or limit current, ISO7821 only needs two external bypass capacitors to operate.

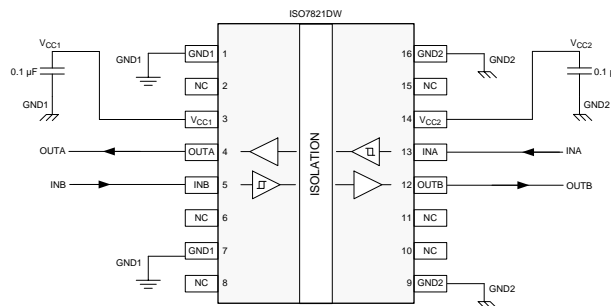

**Figure 17. Typical ISO7821 Circuit Hook-up**

### 9.2.2.1 Electromagnetic Compatibility (EMC) Considerations

Many applications in harsh industrial environment are sensitive to disturbances such as electrostatic discharge (ESD), electrical fast transient (EFT), surge and electromagnetic emissions. These electromagnetic disturbances are regulated by international standards such as IEC 61000-4-x and CISPR 22. Although system-level performance and reliability depends, to a large extent, on the application board design and layout, the ISO7821 incorporate many chip-level design improvements for overall system robustness. Some of these improvements include:

- Robust ESD protection for input and output signal pins and inter-chip bond pads.
- Low-resistance connectivity of ESD cells to supply and ground pins.
- Enhanced performance of high voltage isolation capacitor for better tolerance of ESD, EFT and surge events.
- Bigger on-chip decoupling capacitors to bypass undesirable high energy signals through a low impedance path.
- PMOS and NMOS devices isolated from each other by using guard rings to avoid triggering of parasitic SCRs.
- Reduced common mode currents across the isolation barrier by ensuring purely differential internal operation.

### 9.2.3 Application Performance Curve

Typical eye diagram of ISO7821 indicate low jitter and wide open eye at the maximum data rate of 100 Mbps.

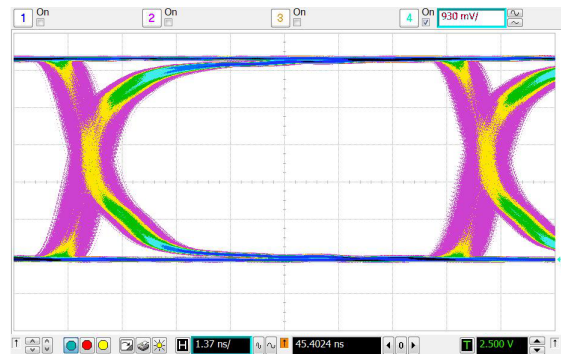

**Figure 18. Eye Diagram at 100 Mbps PRBS, 5 V and 25°C**

## 10 Power Supply Recommendations

To ensure reliable operation at all data rates and supply voltages, a 0.1  $\mu\text{F}$  bypass capacitor is recommended at input and output supply pins ( $V_{CC1}$  and  $V_{CC2}$ ). The capacitors should be placed as close to the supply pins as possible. If only a single primary-side power supply is available in an application, isolated power can be generated for the secondary-side with the help of a transformer driver such as Texas Instruments' [SN6501](#). For such applications, detailed power supply design and transformer selection recommendations are available in [SN6501](#) datasheet ([SLLSEA0](#)) .

## 11 Layout

### 11.1 PCB Material

For digital circuit boards operating below 150 Mbps, (or rise and fall times higher than 1 ns), and trace lengths of up to 10 inches, use standard FR-4 epoxy-glass as PCB material. FR-4 (Flame Retardant 4) meets the requirements of Underwriters Laboratories UL94-V0, and is preferred over cheaper alternatives due to its lower dielectric losses at high frequencies, less moisture absorption, greater strength and stiffness, and its self-extinguishing flammability-characteristics.

### 11.2 Layout Guidelines

A minimum of four layers is required to accomplish a low EMI PCB design (see [Figure 19](#)). Layer stacking should be in the following order (top-to-bottom): high-speed signal layer, ground plane, power plane and low-frequency signal layer.

- Routing the high-speed traces on the top layer avoids the use of vias (and the introduction of their inductances) and allows for clean interconnects between the isolator and the transmitter and receiver circuits of the data link.
- Placing a solid ground plane next to the high-speed signal layer establishes controlled impedance for transmission line interconnects and provides an excellent low-inductance path for the return current flow.
- Placing the power plane next to the ground plane creates additional high-frequency bypass capacitance of approximately 100 pF/in<sup>2</sup>.
- Routing the slower speed control signals on the bottom layer allows for greater flexibility as these signal links usually have margin to tolerate discontinuities such as vias.

If an additional supply voltage plane or signal layer is needed, add a second power / ground plane system to the stack to keep it symmetrical. This makes the stack mechanically stable and prevents it from warping. Also the power and ground plane of each power system can be placed closer together, thus increasing the high-frequency bypass capacitance significantly.

For detailed layout recommendations, see Application Note [SLLA284](#), *Digital Isolator Design Guide*.

### 11.3 Layout Example

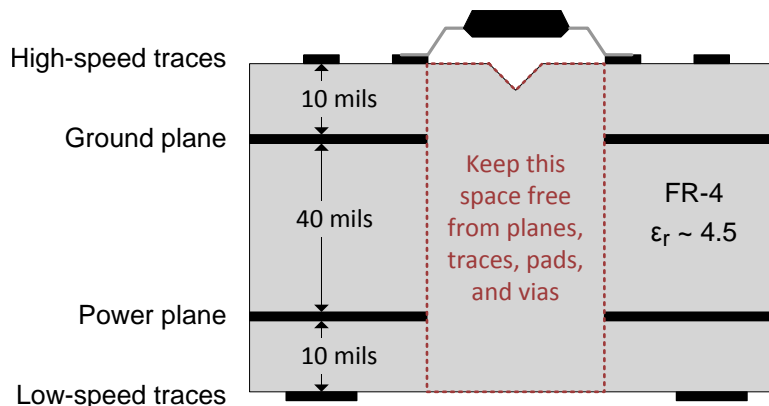

Figure 19. Layout Example

## 12 Device and Documentation Support

### 12.1 Documentation Support

#### 12.1.1 Related Documentation

See the *Isolation Glossary* ([SLLA353](#))

### 12.2 Related Links

The table below lists quick access links. Categories include technical documents, support and community resources, tools and software, and quick access to sample or buy.

**Table 8. Related Links**

PARTS	PRODUCT FOLDER	SAMPLE & BUY	TECHNICAL DOCUMENTS	TOOLS & SOFTWARE	SUPPORT & COMMUNITY
ISO7821	<a href="#">Click here</a>	<a href="#">Click here</a>	<a href="#">Click here</a>	<a href="#">Click here</a>	<a href="#">Click here</a>
ISO7821F	<a href="#">Click here</a>	<a href="#">Click here</a>	<a href="#">Click here</a>	<a href="#">Click here</a>	<a href="#">Click here</a>

### 12.3 Community Resources

The following links connect to TI community resources. Linked contents are provided "AS IS" by the respective contributors. They do not constitute TI specifications and do not necessarily reflect TI's views; see TI's [Terms of Use](#).

**TI E2E™ Online Community** *TI's Engineer-to-Engineer (E2E) Community*. Created to foster collaboration among engineers. At [e2e.ti.com](http://e2e.ti.com), you can ask questions, share knowledge, explore ideas and help solve problems with fellow engineers.

**Design Support** *TI's Design Support* Quickly find helpful E2E forums along with design support tools and contact information for technical support.

### 12.4 Trademarks

E2E is a trademark of Texas Instruments.

### 12.5 Electrostatic Discharge Caution



These devices have limited built-in ESD protection. The leads should be shorted together or the device placed in conductive foam during storage or handling to prevent electrostatic damage to the MOS gates.

### 12.6 Glossary

[SLYZ022](#) — *TI Glossary*.

This glossary lists and explains terms, acronyms, and definitions.

## 13 Mechanical, Packaging, and Orderable Information

The following pages include mechanical packaging and orderable information. This information is the most current data available for the designated devices. This data is subject to change without notice and revision of this document. For browser-based versions of this data sheet, refer to the left-hand navigation.



DW0016B

PACKAGE OUTLINE  
SOIC - 2.65 mm max height

SOIC

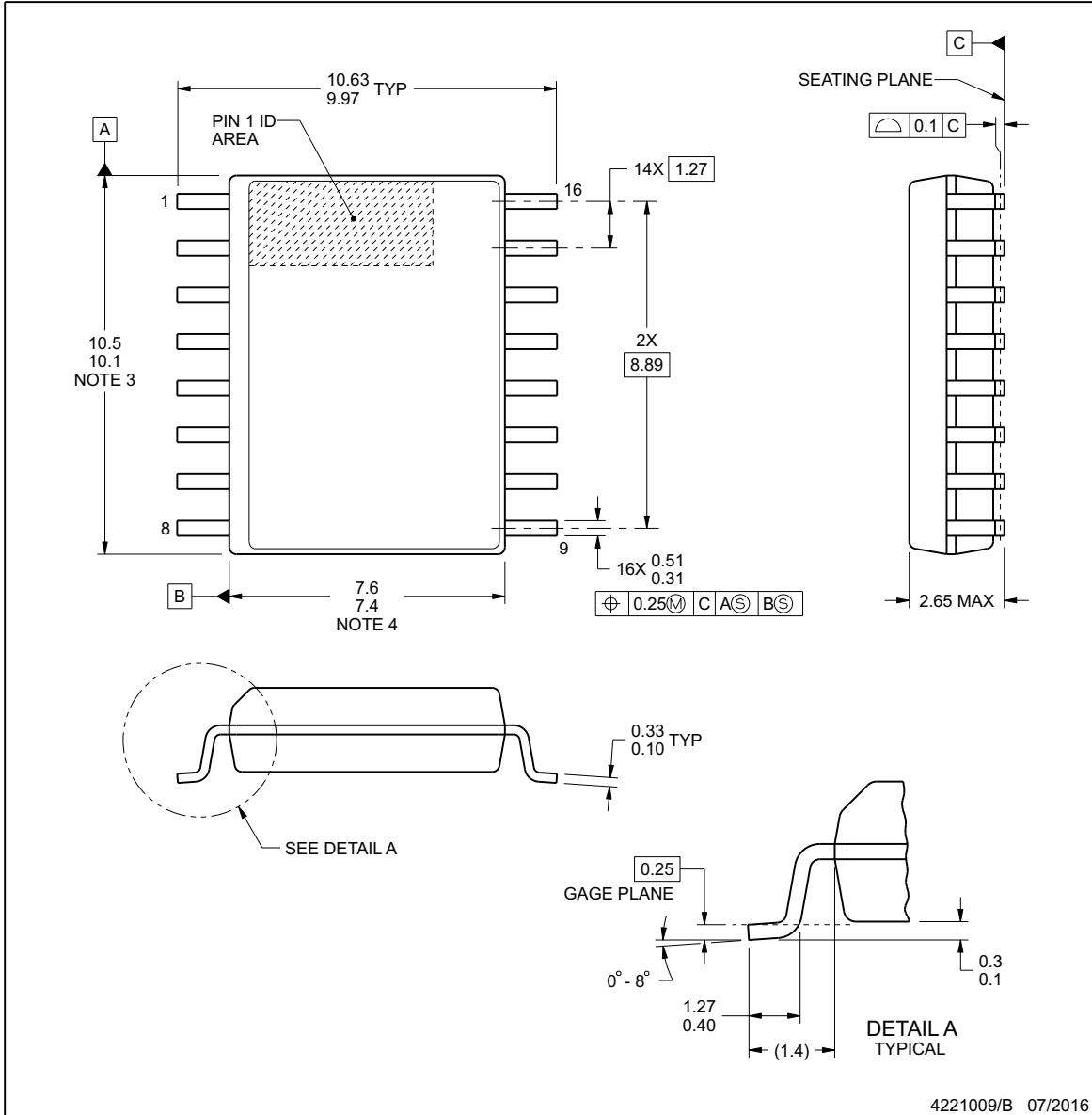

4221009/B 07/2016

NOTES:

1. All linear dimensions are in millimeters. Dimensions in parenthesis are for reference only. Dimensioning and tolerancing per ASME Y14.5M.
2. This drawing is subject to change without notice.
3. This dimension does not include mold flash, protrusions, or gate burrs. Mold flash, protrusions, or gate burrs shall not exceed 0.15 mm, per side.
4. This dimension does not include interlead flash. Interlead flash shall not exceed 0.25 mm, per side.
5. Reference JEDEC registration MS-013.

**EXAMPLE BOARD LAYOUT**

**DW0016B**

**SOIC - 2.65 mm max height**

SOIC

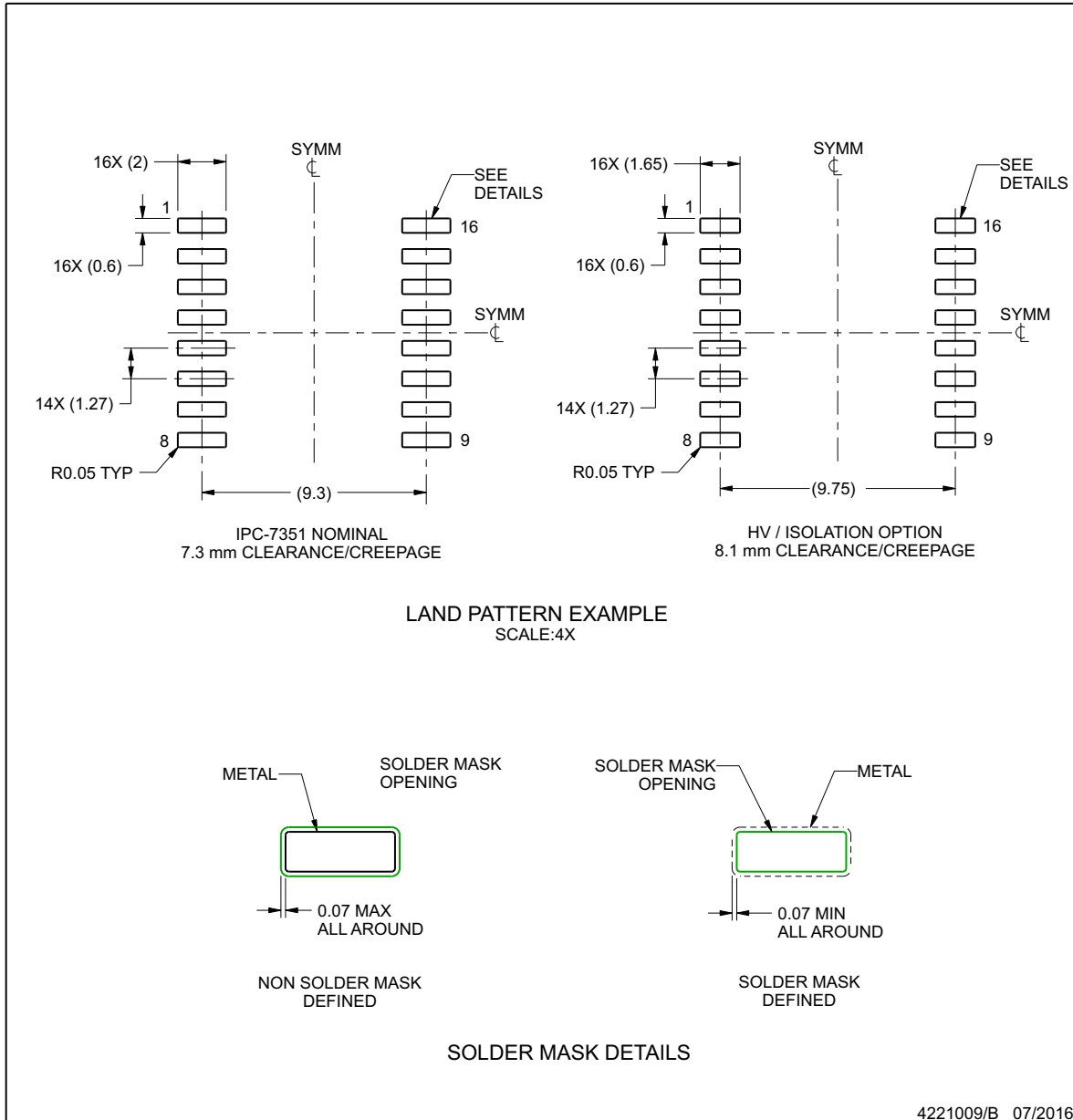

NOTES: (continued)

6. Publication IPC-7351 may have alternate designs.

7. Solder mask tolerances between and around signal pads can vary based on board fabrication site.

## EXAMPLE STENCIL DESIGN

**DW0016B**

**SOIC - 2.65 mm max height**

SOIC

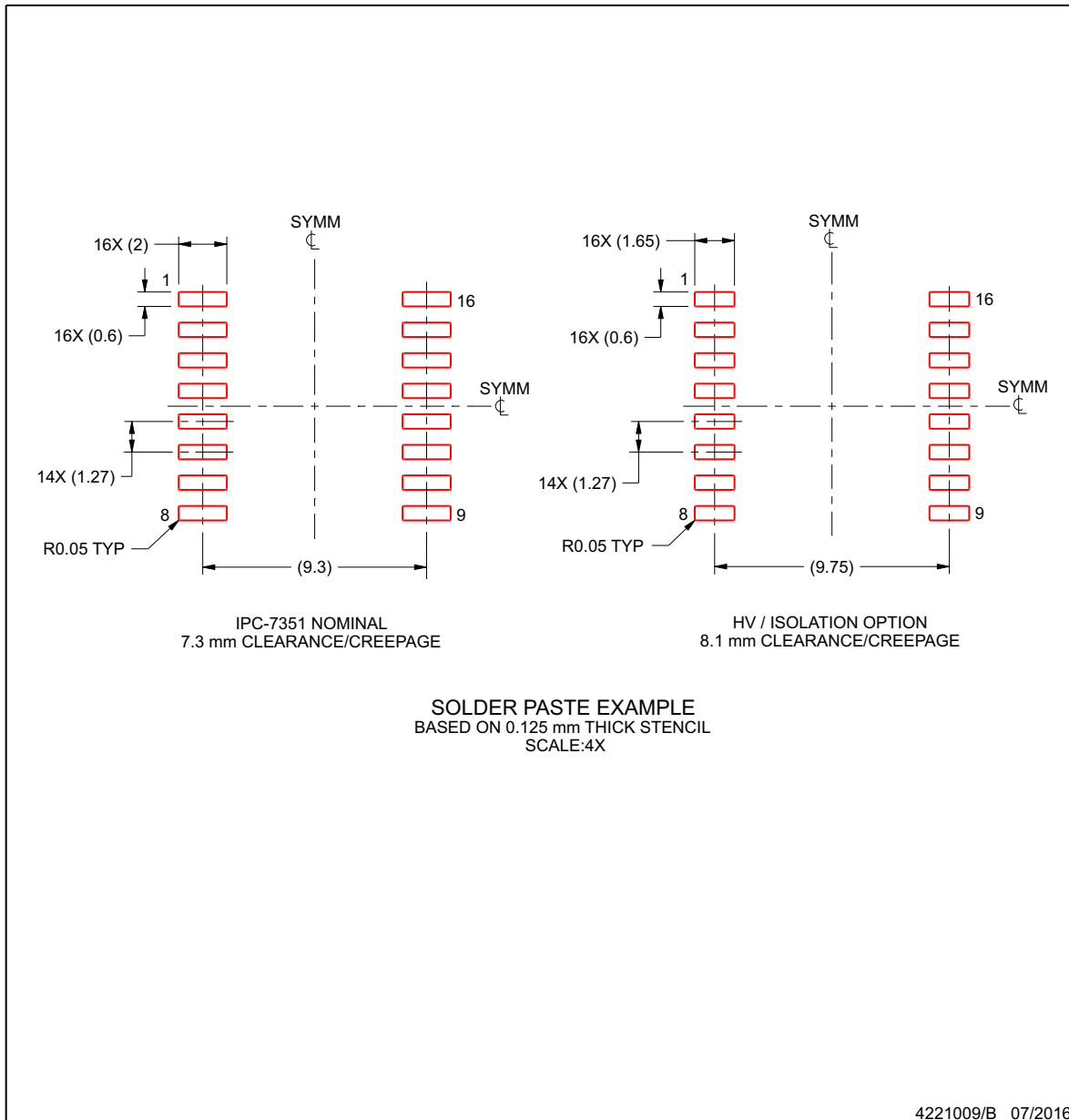

NOTES: (continued)

- 8. Laser cutting apertures with trapezoidal walls and rounded corners may offer better paste release. IPC-7525 may have alternate design recommendations.
- 9. Board assembly site may have different recommendations for stencil design.



**DWW0016A**

**PACKAGE OUTLINE**

**SOIC - 2.65 mm max height**

PLASTIC SMALL OUTLINE

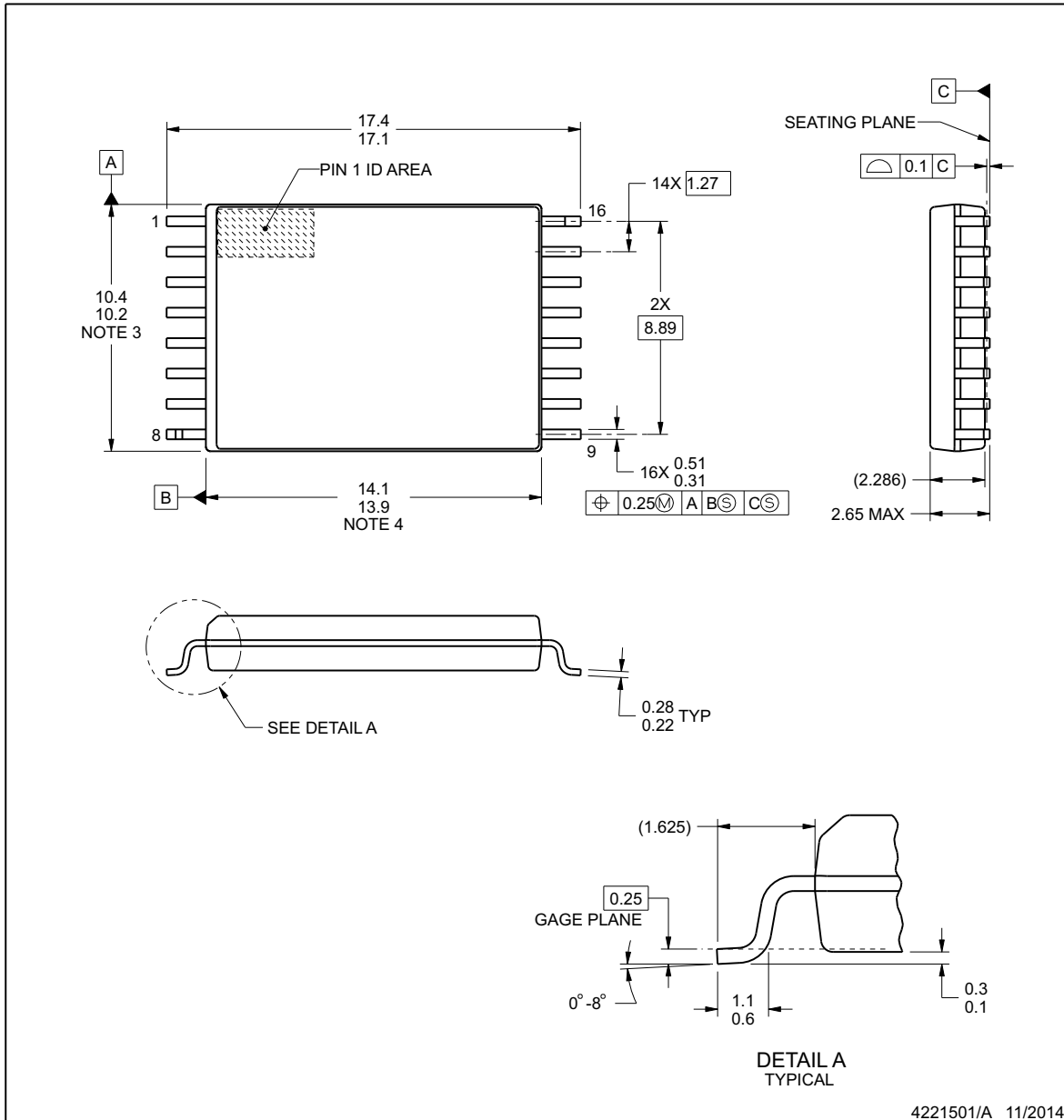

NOTES:

1. All linear dimensions are in millimeters. Any dimensions in parenthesis are for reference only. Dimensioning and tolerancing per ASME Y14.5M.
2. This drawing is subject to change without notice.
3. This dimension does not include mold flash, protrusions, or gate burrs. Mold flash, protrusions, or gate burrs shall not exceed 0.15 mm per side.
4. This dimension does not include interlead flash.

## EXAMPLE BOARD LAYOUT

**DWW0016A**

**SOIC - 2.65 mm max height**

PLASTIC SMALL OUTLINE

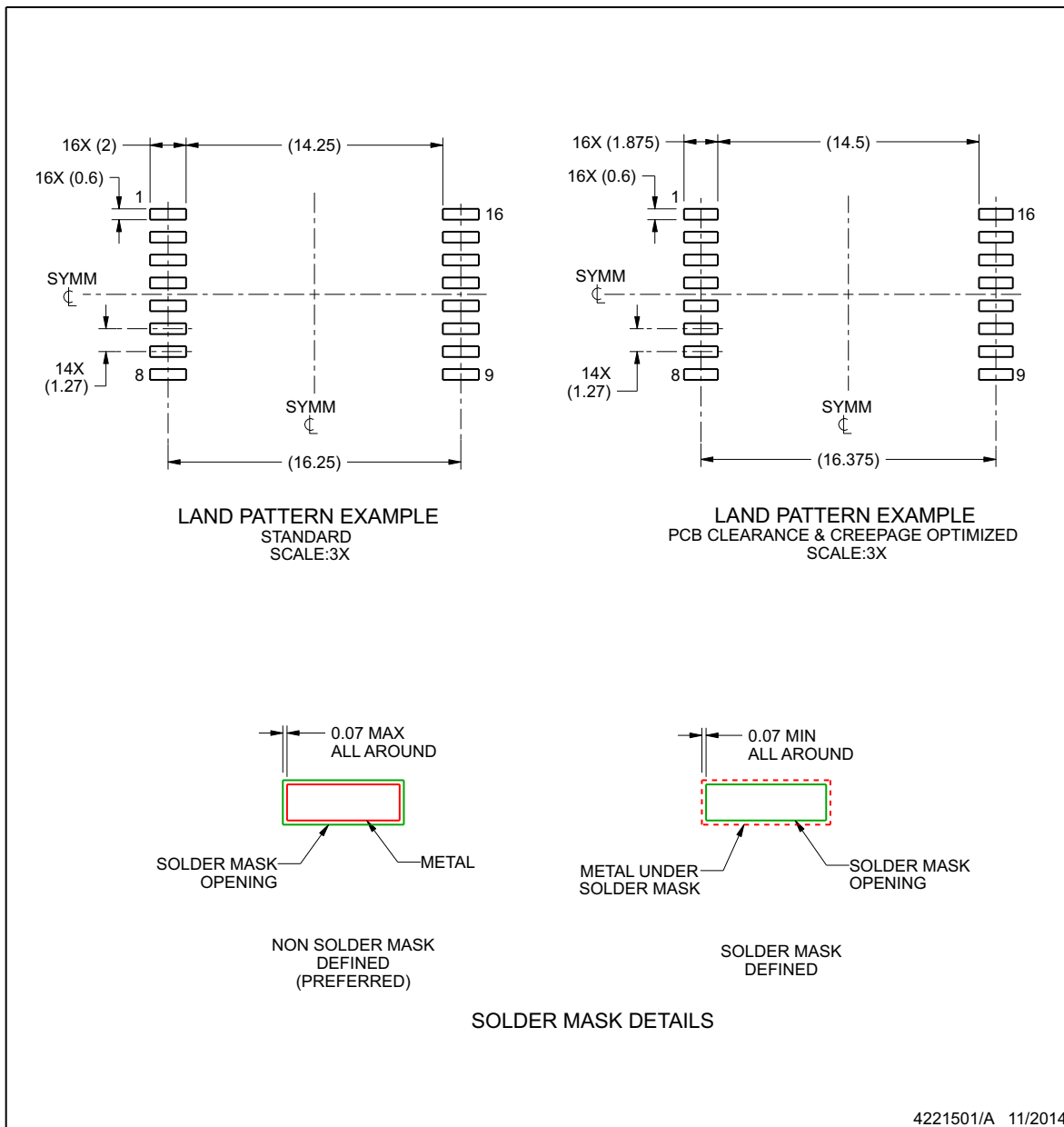

NOTES: (continued)

- 5. Publication IPC-7351 may have alternate designs.
- 6. Solder mask tolerances between and around signal pads can vary based on board fabrication site.

## EXAMPLE STENCIL DESIGN

DWW0016A

SOIC - 2.65 mm max height

PLASTIC SMALL OUTLINE

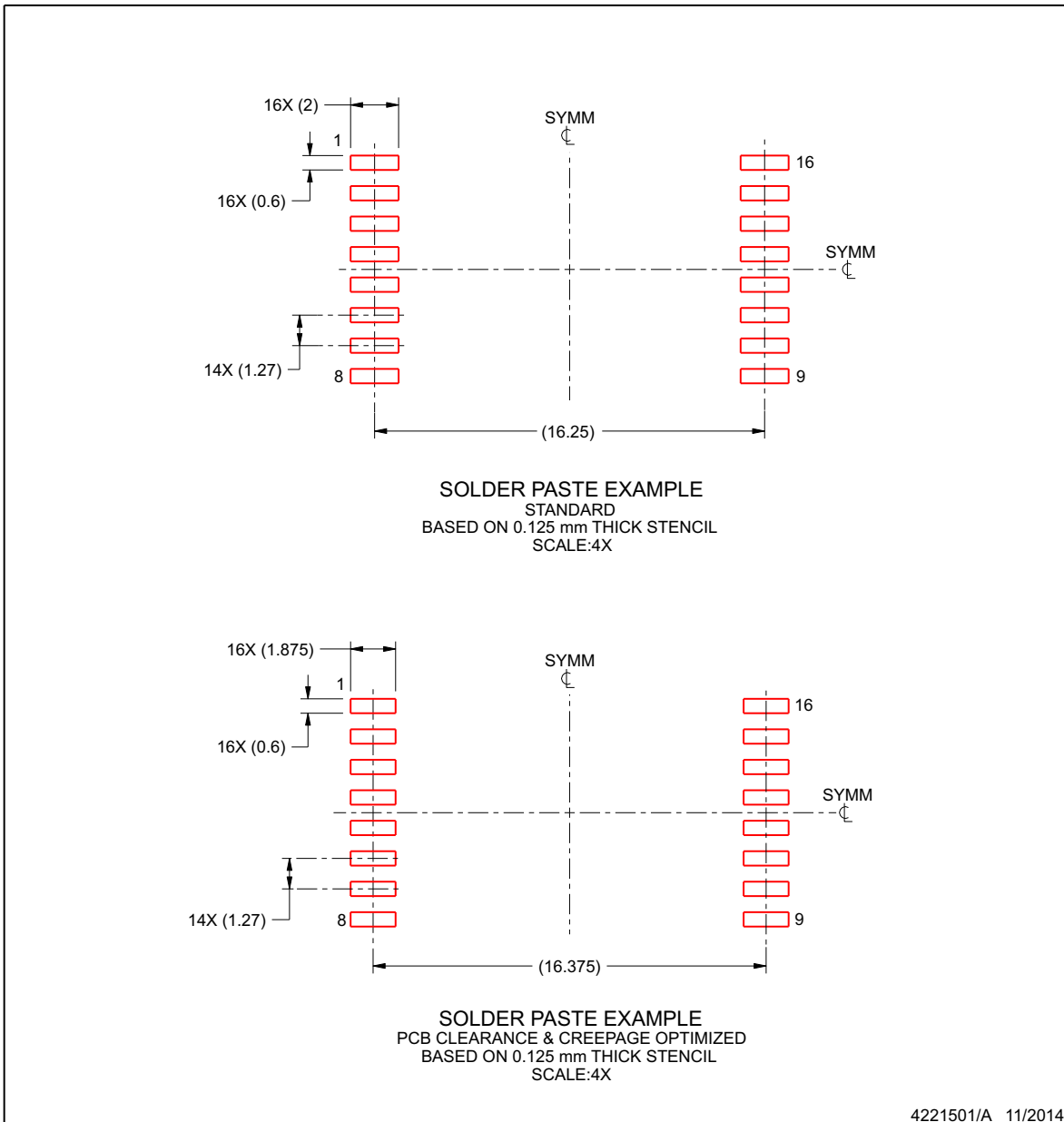

NOTES: (continued)

7. Laser cutting apertures with trapezoidal walls and rounded corners may offer better paste release. IPC-7525 may have alternate design recommendations.
8. Board assembly site may have different recommendations for stencil design.

**PACKAGING INFORMATION**

Orderable Device	Status (1)	Package Type	Package Drawing	Pins	Package Qty	Eco Plan (2)	Lead/Ball Finish (6)	MSL Peak Temp (3)	Op Temp (°C)	Device Marking (4/5)	Samples
ISO7821DW	ACTIVE	SOIC	DW	16	40	Green (RoHS & no Sb/Br)	CU NIPDAU	Level-2-260C-1 YEAR	-55 to 125	ISO7821	<a href="#">Samples</a>
ISO7821DWR	ACTIVE	SOIC	DW	16	2000	Green (RoHS & no Sb/Br)	CU NIPDAU	Level-2-260C-1 YEAR	-55 to 125	ISO7821	<a href="#">Samples</a>
ISO7821DWW	ACTIVE	SOIC	DWW	16	45	Green (RoHS & no Sb/Br)	CU NIPDAU	Level-3-260C-168 HR	-55 to 125	ISO7821	<a href="#">Samples</a>
ISO7821DWWR	ACTIVE	SOIC	DWW	16	1000	Green (RoHS & no Sb/Br)	CU NIPDAU	Level-3-260C-168 HR	-55 to 125	ISO7821	<a href="#">Samples</a>
ISO7821FDW	ACTIVE	SOIC	DW	16	40	Green (RoHS & no Sb/Br)	CU NIPDAU	Level-2-260C-1 YEAR	-55 to 125	ISO7821F	<a href="#">Samples</a>
ISO7821FDWR	ACTIVE	SOIC	DW	16	2000	Green (RoHS & no Sb/Br)	CU NIPDAU	Level-2-260C-1 YEAR	-55 to 125	ISO7821F	<a href="#">Samples</a>
ISO7821FDWW	ACTIVE	SOIC	DWW	16	45	Green (RoHS & no Sb/Br)	CU NIPDAU	Level-3-260C-168 HR	-55 to 125	ISO7821F	<a href="#">Samples</a>
ISO7821FDWWR	ACTIVE	SOIC	DWW	16	1000	Green (RoHS & no Sb/Br)	CU NIPDAU	Level-3-260C-168 HR	-55 to 125	ISO7821F	<a href="#">Samples</a>

(1) The marketing status values are defined as follows:

**ACTIVE:** Product device recommended for new designs.

**LIFEBUY:** TI has announced that the device will be discontinued, and a lifetime-buy period is in effect.

**NRND:** Not recommended for new designs. Device is in production to support existing customers, but TI does not recommend using this part in a new design.

**PREVIEW:** Device has been announced but is not in production. Samples may or may not be available.

**OBSELETE:** TI has discontinued the production of the device.

(2) Eco Plan - The planned eco-friendly classification: Pb-Free (RoHS), Pb-Free (RoHS Exempt), or Green (RoHS & no Sb/Br) - please check <http://www.ti.com/productcontent> for the latest availability information and additional product content details.

**TBD:** The Pb-Free/Green conversion plan has not been defined.

**Pb-Free (RoHS):** TI's terms "Lead-Free" or "Pb-Free" mean semiconductor products that are compatible with the current RoHS requirements for all 6 substances, including the requirement that lead not exceed 0.1% by weight in homogeneous materials. Where designed to be soldered at high temperatures, TI Pb-Free products are suitable for use in specified lead-free processes.

**Pb-Free (RoHS Exempt):** This component has a RoHS exemption for either 1) lead-based flip-chip solder bumps used between the die and package, or 2) lead-based die adhesive used between the die and leadframe. The component is otherwise considered Pb-Free (RoHS compatible) as defined above.

**Green (RoHS & no Sb/Br):** TI defines "Green" to mean Pb-Free (RoHS compatible), and free of Bromine (Br) and Antimony (Sb) based flame retardants (Br or Sb do not exceed 0.1% by weight in homogeneous material)

(3) MSL, Peak Temp. - The Moisture Sensitivity Level rating according to the JEDEC industry standard classifications, and peak solder temperature.

(4) There may be additional marking, which relates to the logo, the lot trace code information, or the environmental category on the device.

(5) Multiple Device Markings will be inside parentheses. Only one Device Marking contained in parentheses and separated by a "~" will appear on a device. If a line is indented then it is a continuation of the previous line and the two combined represent the entire Device Marking for that device.

(6) Lead/Ball Finish - Orderable Devices may have multiple material finish options. Finish options are separated by a vertical ruled line. Lead/Ball Finish values may wrap to two lines if the finish value exceeds the maximum column width.

**Important Information and Disclaimer:**The information provided on this page represents TI's knowledge and belief as of the date that it is provided. TI bases its knowledge and belief on information provided by third parties, and makes no representation or warranty as to the accuracy of such information. Efforts are underway to better integrate information from third parties. TI has taken and continues to take reasonable steps to provide representative and accurate information but may not have conducted destructive testing or chemical analysis on incoming materials and chemicals. TI and TI suppliers consider certain information to be proprietary, and thus CAS numbers and other limited information may not be available for release.

In no event shall TI's liability arising out of such information exceed the total purchase price of the TI part(s) at issue in this document sold by TI to Customer on an annual basis.

**TAPE AND REEL INFORMATION**

**QUADRANT ASSIGNMENTS FOR PIN 1 ORIENTATION IN TAPE**

\*All dimensions are nominal

Device	Package Type	Package Drawing	Pins	SPQ	Reel Diameter (mm)	Reel Width W1 (mm)	A0 (mm)	B0 (mm)	K0 (mm)	P1 (mm)	W (mm)	Pin1 Quadrant
ISO7821DWR	SOIC	DW	16	2000	330.0	16.4	10.75	10.7	2.7	12.0	16.0	Q1
ISO7821DWWR	SOIC	DWW	16	1000	330.0	24.4	18.0	10.0	3.0	20.0	24.0	Q1
ISO7821FDWR	SOIC	DW	16	2000	330.0	16.4	10.75	10.7	2.7	12.0	16.0	Q1
ISO7821FDWWR	SOIC	DWW	16	1000	330.0	24.4	18.0	10.0	3.0	20.0	24.0	Q1

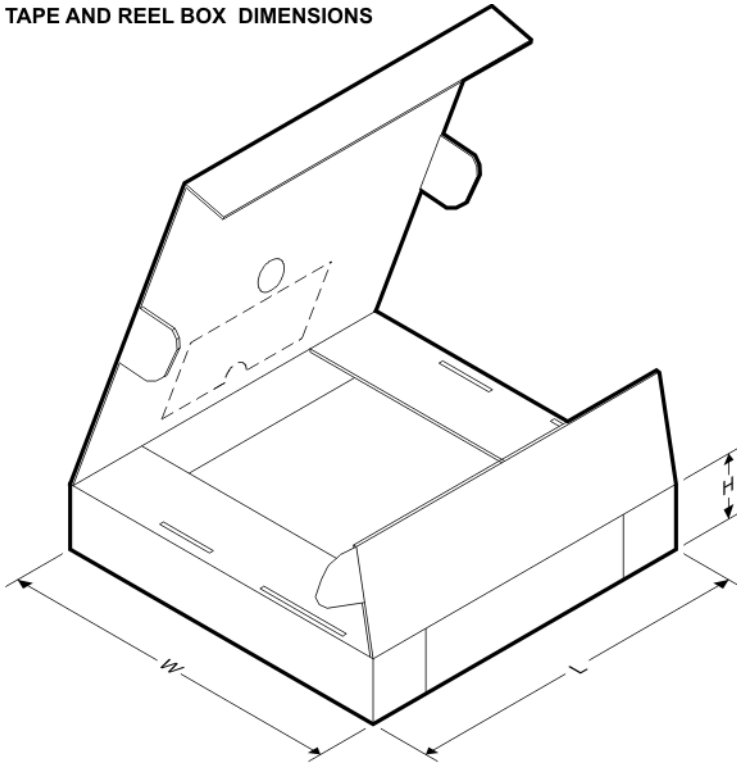
**TAPE AND REEL BOX DIMENSIONS**

\*All dimensions are nominal

Device	Package Type	Package Drawing	Pins	SPQ	Length (mm)	Width (mm)	Height (mm)
ISO7821DWR	SOIC	DW	16	2000	367.0	367.0	38.0
ISO7821DWWR	SOIC	DWW	16	1000	367.0	367.0	45.0
ISO7821FDWR	SOIC	DW	16	2000	367.0	367.0	38.0
ISO7821FDWWR	SOIC	DWW	16	1000	367.0	367.0	45.0

## IMPORTANT NOTICE

Texas Instruments Incorporated (TI) reserves the right to make corrections, enhancements, improvements and other changes to its semiconductor products and services per JESD46, latest issue, and to discontinue any product or service per JESD48, latest issue. Buyers should obtain the latest relevant information before placing orders and should verify that such information is current and complete.

TI's published terms of sale for semiconductor products (<http://www.ti.com/sc/docs/stdterms.htm>) apply to the sale of packaged integrated circuit products that TI has qualified and released to market. Additional terms may apply to the use or sale of other types of TI products and services.

Reproduction of significant portions of TI information in TI data sheets is permissible only if reproduction is without alteration and is accompanied by all associated warranties, conditions, limitations, and notices. TI is not responsible or liable for such reproduced documentation. Information of third parties may be subject to additional restrictions. Resale of TI products or services with statements different from or beyond the parameters stated by TI for that product or service voids all express and any implied warranties for the associated TI product or service and is an unfair and deceptive business practice. TI is not responsible or liable for any such statements.

Buyers and others who are developing systems that incorporate TI products (collectively, "Designers") understand and agree that Designers remain responsible for using their independent analysis, evaluation and judgment in designing their applications and that Designers have full and exclusive responsibility to assure the safety of Designers' applications and compliance of their applications (and of all TI products used in or for Designers' applications) with all applicable regulations, laws and other applicable requirements. Designer represents that, with respect to their applications, Designer has all the necessary expertise to create and implement safeguards that (1) anticipate dangerous consequences of failures, (2) monitor failures and their consequences, and (3) lessen the likelihood of failures that might cause harm and take appropriate actions. Designer agrees that prior to using or distributing any applications that include TI products, Designer will thoroughly test such applications and the functionality of such TI products as used in such applications.

TI's provision of technical, application or other design advice, quality characterization, reliability data or other services or information, including, but not limited to, reference designs and materials relating to evaluation modules, (collectively, "TI Resources") are intended to assist designers who are developing applications that incorporate TI products; by downloading, accessing or using TI Resources in any way, Designer (individually or, if Designer is acting on behalf of a company, Designer's company) agrees to use any particular TI Resource solely for this purpose and subject to the terms of this Notice.

TI's provision of TI Resources does not expand or otherwise alter TI's applicable published warranties or warranty disclaimers for TI products, and no additional obligations or liabilities arise from TI providing such TI Resources. TI reserves the right to make corrections, enhancements, improvements and other changes to its TI Resources. TI has not conducted any testing other than that specifically described in the published documentation for a particular TI Resource.

Designer is authorized to use, copy and modify any individual TI Resource only in connection with the development of applications that include the TI product(s) identified in such TI Resource. NO OTHER LICENSE, EXPRESS OR IMPLIED, BY ESTOPPEL OR OTHERWISE TO ANY OTHER TI INTELLECTUAL PROPERTY RIGHT, AND NO LICENSE TO ANY TECHNOLOGY OR INTELLECTUAL PROPERTY RIGHT OF TI OR ANY THIRD PARTY IS GRANTED HEREIN, including but not limited to any patent right, copyright, mask work right, or other intellectual property right relating to any combination, machine, or process in which TI products or services are used. Information regarding or referencing third-party products or services does not constitute a license to use such products or services, or a warranty or endorsement thereof. Use of TI Resources may require a license from a third party under the patents or other intellectual property of the third party, or a license from TI under the patents or other intellectual property of TI.

TI RESOURCES ARE PROVIDED "AS IS" AND WITH ALL FAULTS. TI DISCLAIMS ALL OTHER WARRANTIES OR REPRESENTATIONS, EXPRESS OR IMPLIED, REGARDING RESOURCES OR USE THEREOF, INCLUDING BUT NOT LIMITED TO ACCURACY OR COMPLETENESS, TITLE, ANY EPIDEMIC FAILURE WARRANTY AND ANY IMPLIED WARRANTIES OF MERCHANTABILITY, FITNESS FOR A PARTICULAR PURPOSE, AND NON-INFRINGEMENT OF ANY THIRD PARTY INTELLECTUAL PROPERTY RIGHTS. TI SHALL NOT BE LIABLE FOR AND SHALL NOT DEFEND OR INDEMNIFY DESIGNER AGAINST ANY CLAIM, INCLUDING BUT NOT LIMITED TO ANY INFRINGEMENT CLAIM THAT RELATES TO OR IS BASED ON ANY COMBINATION OF PRODUCTS EVEN IF DESCRIBED IN TI RESOURCES OR OTHERWISE. IN NO EVENT SHALL TI BE LIABLE FOR ANY ACTUAL, DIRECT, SPECIAL, COLLATERAL, INDIRECT, PUNITIVE, INCIDENTAL, CONSEQUENTIAL OR EXEMPLARY DAMAGES IN CONNECTION WITH OR ARISING OUT OF TI RESOURCES OR USE THEREOF, AND REGARDLESS OF WHETHER TI HAS BEEN ADVISED OF THE POSSIBILITY OF SUCH DAMAGES.

Unless TI has explicitly designated an individual product as meeting the requirements of a particular industry standard (e.g., ISO/TS 16949 and ISO 26262), TI is not responsible for any failure to meet such industry standard requirements.

Where TI specifically promotes products as facilitating functional safety or as compliant with industry functional safety standards, such products are intended to help enable customers to design and create their own applications that meet applicable functional safety standards and requirements. Using products in an application does not by itself establish any safety features in the application. Designers must ensure compliance with safety-related requirements and standards applicable to their applications. Designer may not use any TI products in life-critical medical equipment unless authorized officers of the parties have executed a special contract specifically governing such use. Life-critical medical equipment is medical equipment where failure of such equipment would cause serious bodily injury or death (e.g., life support, pacemakers, defibrillators, heart pumps, neurostimulators, and implantables). Such equipment includes, without limitation, all medical devices identified by the U.S. Food and Drug Administration as Class III devices and equivalent classifications outside the U.S.

TI may expressly designate certain products as completing a particular qualification (e.g., Q100, Military Grade, or Enhanced Product). Designers agree that it has the necessary expertise to select the product with the appropriate qualification designation for their applications and that proper product selection is at Designers' own risk. Designers are solely responsible for compliance with all legal and regulatory requirements in connection with such selection.

Designer will fully indemnify TI and its representatives against any damages, costs, losses, and/or liabilities arising out of Designer's non-compliance with the terms and provisions of this Notice.