

## TMP303 Easy-To-Use, Low-Power, 1°C, Low-Supply Temperature Range Monitor In Micropackage

### 1 Features

- Low Power: 5  $\mu$ A (Maximum)
- SOT-563 Package: 1.60 × 1.60 × 0.6 mm
- Trip Point Accuracy:
  - $\pm 0.2^\circ\text{C}$  (Typical) from  $-40^\circ\text{C}$  to  $125^\circ\text{C}$
- Push-Pull Output
- Selectable Hysteresis: 1/2/5/10°C
- Supply Voltage Range: 1.4 V to 3.6 V

### 2 Applications

- Battery Charging
- Consumer Electronics
- Enterprise
- Telecom

### 3 Description

The TMP303 devices are temperature range monitors that offer design flexibility through an extra small footprint (SOT-563), low power (5  $\mu$ A maximum) and low supply voltage capability (as low as 1.4 V).

These devices require no additional components for operation; each can function independent of microprocessors or microcontrollers.

There are four trip points available see [Device Options](#). Trip points can be programmed at the factory to any desired temperature. For applications that require different values, contact your local TI representative.

The OUT pin is a push-pull, active-high output. When the measured temperature is beyond the trip point range, and the Set Output High (SOH) pin is low, the OUT pin is high. The SOH pin is an input pin with an internal pulldown resistor. When the SOH pin is forced high, the OUT pin goes high regardless of the measured temperature.

#### Device Information<sup>(1)</sup>

PART NUMBER	PACKAGE	BODY SIZE (NOM)
TMP303	SOT-563 (6)	1.60 mm × 1.20 mm

(1) For all available packages, see the orderable addendum at the end of the data sheet.

**TMP303 Functional Block Diagram**

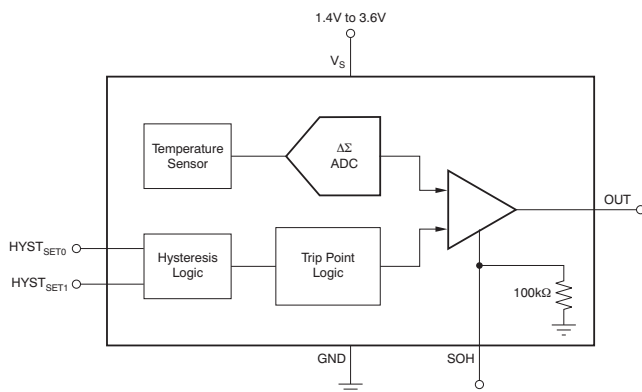

**Trip Threshold Accuracy**

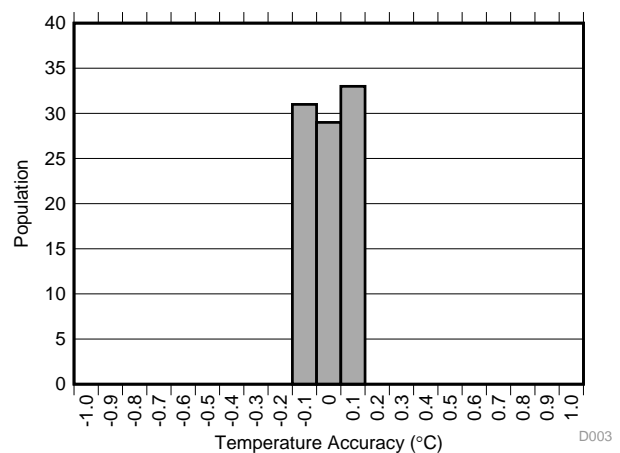

D003



## Table of Contents

<b>1 Features</b> .....	<b>1</b>	8.3 Feature Description.....	<b>9</b>
<b>2 Applications</b> .....	<b>1</b>	8.4 Device Functional Modes.....	<b>11</b>
<b>3 Description</b> .....	<b>1</b>	<b>9 Application and Implementation</b> .....	<b>12</b>
<b>4 Revision History</b> .....	<b>2</b>	9.1 Application Information.....	<b>12</b>
<b>5 Device Options</b> .....	<b>3</b>	9.2 Typical Applications .....	<b>12</b>
<b>6 Pin Configuration and Functions</b> .....	<b>3</b>	<b>10 Power Supply Recommendations</b> .....	<b>16</b>
<b>7 Specifications</b> .....	<b>4</b>	<b>11 Layout</b> .....	<b>16</b>
7.1 Absolute Maximum Ratings .....	<b>4</b>	11.1 Layout Guidelines .....	<b>16</b>
7.2 ESD Ratings.....	<b>4</b>	11.2 Layout Example .....	<b>16</b>
7.3 Recommended Operating Conditions.....	<b>4</b>	<b>12 Device and Documentation Support</b> .....	<b>17</b>
7.4 Thermal Information .....	<b>4</b>	12.1 Community Resources.....	<b>17</b>
7.5 Electrical Characteristics.....	<b>5</b>	12.2 Trademarks .....	<b>17</b>
7.6 Typical Characteristics.....	<b>6</b>	12.3 Electrostatic Discharge Caution.....	<b>17</b>
<b>8 Detailed Description</b> .....	<b>8</b>	12.4 Glossary .....	<b>17</b>
8.1 Overview .....	<b>8</b>	<b>13 Mechanical, Packaging, and Orderable Information</b> .....	<b>17</b>
8.2 Functional Block Diagram .....	<b>8</b>		

## 4 Revision History

NOTE: Page numbers for previous revisions may differ from page numbers in the current version.

<b>Changes from Revision E (October 2015) to Revision F</b>	<b>Page</b>
• Added cross reference to Device Option Table. ....	<b>1</b>
• Added new image for Trip Threshold Accuracy .....	<b>1</b>
• Added Trip Points covering range -20 to 125°C .....	<b>5</b>
• Added Trip Accuracy Error vs Temperature graph. ....	<b>6</b>
<hr/>	
<b>Changes from Revision D (September 2015) to Revision E</b>	<b>Page</b>
• Changed I/O value of HYST <sub>SET1</sub> row in <i>Pin Functions</i> table .....	<b>3</b>
<hr/>	
<b>Changes from Revision C (September 2015) to Revision D</b>	<b>Page</b>
• Consolidated part number to a generic TMP303.....	<b>1</b>
• Deleted the <i>Related Links</i> section. ....	<b>17</b>
<hr/>	
<b>Changes from Revision B (January 2011) to Revision C</b>	<b>Page</b>
• Added <i>ESD Ratings</i> table, <i>Feature Description</i> section, <i>Device Functional Modes</i> , <i>Application and Implementation</i> section, <i>Power Supply Recommendations</i> section, <i>Layout</i> section, <i>Device and Documentation Support</i> section, and <i>Mechanical, Packaging, and Orderable Information</i> section .....	<b>1</b>
<hr/>	
<b>Changes from Revision A (September 2009) to Revision B</b>	<b>Page</b>
• Added TMP303B device to data sheet.....	<b>1</b>

## 5 Device Options

DEVICE	TRIP POINTS (°C)
TMP303A	$T_L = 0, T_H = 60^{(1)}$
TMP303B	$T_L = 0, T_H = 55^{(1)}$
TMP303C	$T_L = -20, T_H = 60^{(1)}$
TMP303D	$T_L = -15, T_H = 125^{(1)}$

(1) Contact a TI representative for other trip points.

## 6 Pin Configuration and Functions

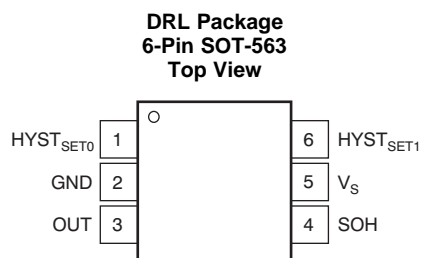

### Pin Functions

PIN		I/O	DESCRIPTION
NAME	NO.		
HYST <sub>SET0</sub>	1	Digital Input	This pin is used to set the amount of thermal hysteresis.
GND	2	Ground	Ground
OUT	3	Digital Output	Active high, push-pull output pin. Does not require a pullup resistor to $V_S$ .
SOH	4	Digital Input	Set output high (SOH) pin. If the SOH pin is pulled high, the TMP303 forces the output high. If the SOH pin is grounded or left floating, this pin has no effect on the behavior of the TMP303.
$V_S$	5	Power Supply	Power supply
HYST <sub>SET1</sub>	6	Digital Input	This pin is used to set the amount of thermal hysteresis.

## 7 Specifications

### 7.1 Absolute Maximum Ratings

over operating free-air temperature range (unless otherwise noted)<sup>(1)</sup>

		MIN	MAX	UNIT
Supply Voltage, $V_S - GND$			3.6	V
Input Pins, Voltage	SOH, HYST <sub>SET1</sub> , HYST <sub>SET0</sub>	-0.5	$V_S + 0.5$	V
Output Pin, Voltage	OUT	-0.5	$V_S + 0.5$	V
Output Pin, Current	OUT	-55	8	mA
Operating Temperature			130	°C
Junction Temperature, $T_J$ max			150	°C
Storage Temperature, $T_{stg}$		-60	150	°C

- (1) Stresses beyond those listed under *Absolute Maximum Ratings* may cause permanent damage to the device. These are stress ratings only, which do not imply functional operation of the device at these or any other conditions beyond those indicated under *Recommended Operating Conditions*. Exposure to absolute-maximum-rated conditions for extended periods may affect device reliability.

### 7.2 ESD Ratings

		VALUE	UNIT
$V_{(ESD)}$ Electrostatic discharge	Human-body model (HBM), per ANSI/ESDA/JEDEC JS-001 <sup>(1)</sup>	±2000	V
	Charged-device model (CDM), per JEDEC specification JESD22-C101 <sup>(2)</sup>	±1000	
	Machine model (MM)	±200	

- (1) JEDEC document JEP155 states that 500-V HBM allows safe manufacturing with a standard ESD control process.

- (2) JEDEC document JEP157 states that 250-V CDM allows safe manufacturing with a standard ESD control process.

### 7.3 Recommended Operating Conditions

over operating free-air temperature range (unless otherwise noted)

		MIN	NOM	MAX	UNIT
$V_S$	Power Supply Voltage	1.4		3.6	V
$T_A$	Specified Temperature Range	-40		125	°C

### 7.4 Thermal Information

THERMAL METRIC <sup>(1)</sup>		TMP303	UNIT
		DRL (SOT-563)	
		6 PINS	
$R_{\theta JA}$	Junction-to-ambient thermal resistance	168	°C/W
$R_{\theta JC(top)}$	Junction-to-case (top) thermal resistance	2.4	°C/W
$R_{\theta JB}$	Junction-to-board thermal resistance	42.3	°C/W
$\Psi_{JT}$	Junction-to-top characterization parameter	0.9	°C/W
$\Psi_{JB}$	Junction-to-board characterization parameter	42.3	°C/W
$R_{\theta JC(bot)}$	Junction-to-case (bottom) thermal resistance	N/A	°C/W

- (1) For more information about traditional and new thermal metrics, see the *Semiconductor and IC Package Thermal Metrics* application report, [SPRA953](#).

## 7.5 Electrical Characteristics

At  $T_A = -40^\circ\text{C}$  to  $125^\circ\text{C}$  and  $V_S = 1.4\text{ V}$  to  $3.6\text{ V}$ , unless otherwise noted.<sup>(1)</sup>

PARAMETER		CONDITIONS	MIN	TYP	MAX	UNIT
<b>TEMPERATURE MEASUREMENT</b>						
$T_L, T_H$ Trip Point Accuracy <sup>(2)</sup>	$T_A = 55^\circ\text{C}$ to $60^\circ\text{C}$ , $V_S = 3.3\text{ V}$			$\pm 0.2$	$\pm 1$	°C
	$T_A = -20$ to $60^\circ\text{C}$ , $V_S = 1.4\text{ V}$ to $3.6\text{ V}$			$\pm 0.2$	$\pm 1.5$	
	$T_A = -20$ to $125^\circ\text{C}$ , $V_S = 1.4\text{ V}$ to $3.6\text{ V}$			$\pm 0.2$	$\pm 2.0$	
	vs Supply				$\pm 0.1$	°C/V
Hysteresis		See <a href="#">Bit Setting vs Hysteresis Window</a>	1		10	°C
<b>HYSTERESIS SET INPUT</b>						
Input Logic Levels	$V_{IH}$		$0.7 \times V_S$		3.6	V
	$V_{IL}$		-0.5		$0.3 \times V_S$	
Input Current	$I_{IN}$	$0 < V_{IN} < 3.6\text{ V}$			1	µA
<b>SOH INPUT</b>						
Pulldown Resistor Value			80	100	120	kΩ
Input Logic Levels	$V_{IH}$		$0.7 \times V_S$		3.6	V
	$V_{IL}$		-0.5		$0.3 \times V_S$	
Input Current		$V_{IN} = 3.6\text{ V}$		36		µA
<b>OUTPUT</b>						
Output Logic Levels	$V_{OH}$	$V_S > 2\text{ V}$ , $I_{OH} = 0.5\text{ mA}$	$V_S - 0.4$		$V_S$	V
		$V_S < 2\text{ V}$ , $I_{OH} = 0.5\text{ mA}$	$V_S - 0.2 \times (V_S)$		$V_S$	
	$V_{OL}$	$V_S > 2\text{ V}$ , $I_{OL} = 1\text{ mA}$	0		0.4	
		$V_S < 2\text{ V}$ , $I_{OL} = 1\text{ mA}$	0		$0.2 \times V_S$	
<b>POWER SUPPLY</b>						
Specified Supply Voltage Range	$V_S$		1.4		3.6	V
Power-up Start-up Time		$V_S > 1.4\text{ V}$	20	28	35	ms
Quiescent Current	$I_Q$	$T_A = -55^\circ\text{C}$ to $60^\circ\text{C}$		3.5	5	µA
		$T_A = -40^\circ\text{C}$ to $125^\circ\text{C}$		4	8	
<b>TEMPERATURE RANGE</b>						
Specified Range			-40		125	°C
Operating Range			-55		130	°C

(1) 100% of all units are production tested at  $T_A = 25^\circ\text{C}$ . Over temperature specifications are specified by design.

(2)  $T_L, T_H$  are device-specific. For example, TMP303A  $T_L = 0^\circ\text{C}$ ,  $T_H = 60^\circ\text{C}$ ; TMP303B  $T_L = 0^\circ\text{C}$ ,  $T_H = 55^\circ\text{C}$ ; TMP303C  $T_L = -20^\circ\text{C}$ ,  $T_H = 60^\circ\text{C}$ ; TMP303D  $T_L = -15^\circ\text{C}$ ,  $T_H = 125^\circ\text{C}$

## 7.6 Typical Characteristics

At  $V_S = 3.3\text{ V}$  and  $T_A = 25^\circ\text{C}$ , unless otherwise noted.

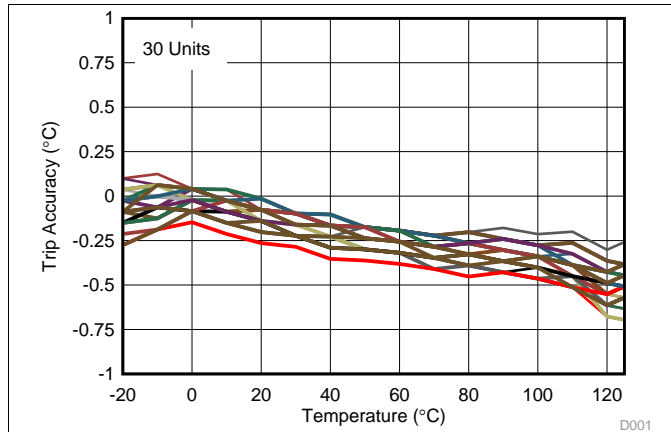

Figure 1. Trip Accuracy Error vs Temperature

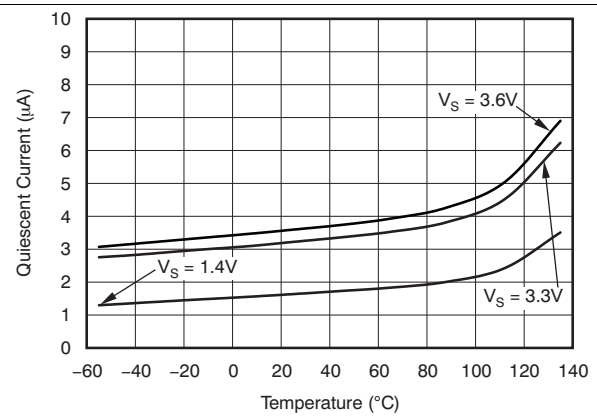

Figure 2. Quiescent Current vs Temperature

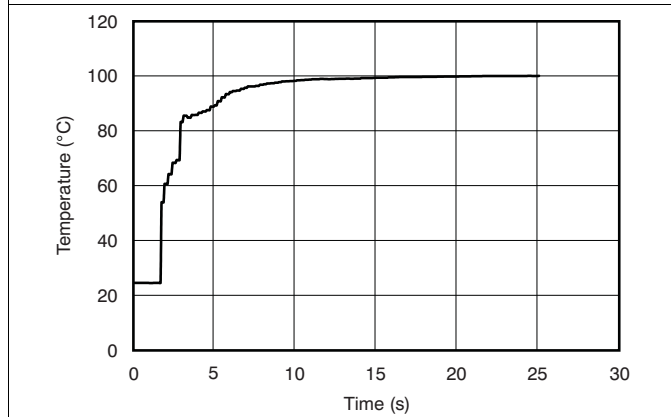

Figure 3. Temperature Step Response in Perfluorinated Fluid at  $100^\circ\text{C}$  vs Time

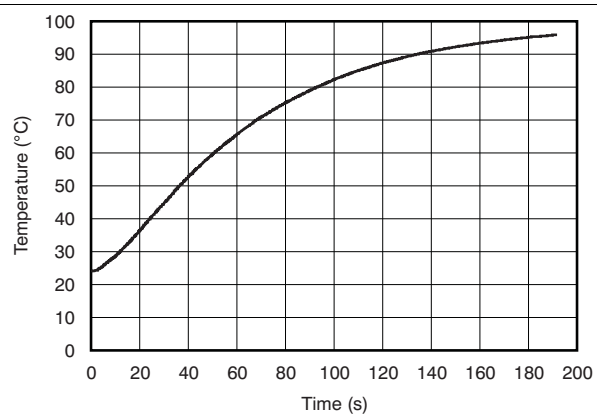

Figure 4. Thermal Step Response in Air at  $100^\circ\text{C}$  vs Time

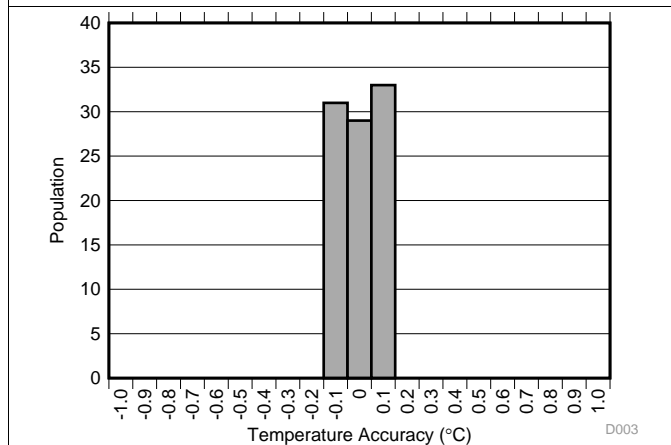

Figure 5. Trip Threshold Accuracy at  $-20^\circ\text{C}$  to  $125^\circ\text{C}$

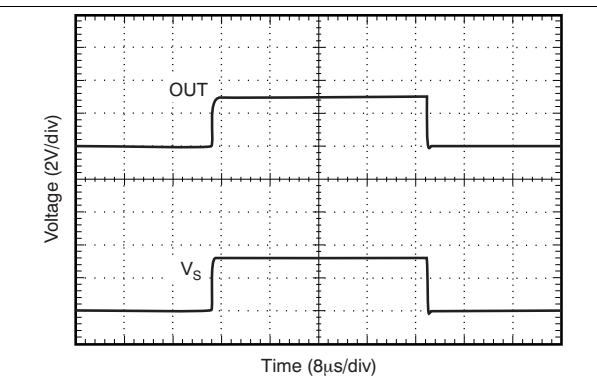
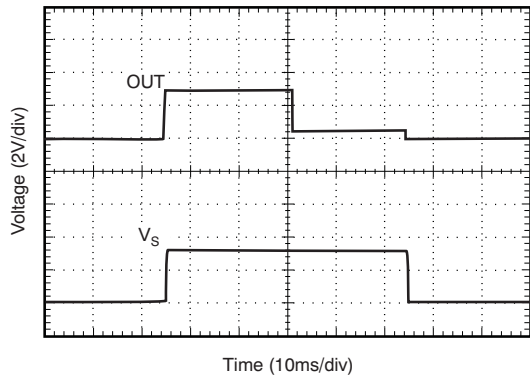

Figure 6. Power-Up and Power-Down Transient Response

**Typical Characteristics (continued)**

At  $V_S = 3.3\text{ V}$  and  $T_A = 25^\circ\text{C}$ , unless otherwise noted.



**Figure 7. Power-Up, Trip, and Power-Down Response**

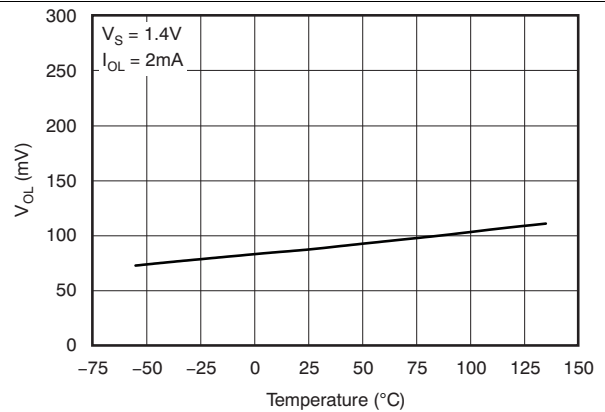

**Figure 8. Output Logic Level Low vs Temperature**

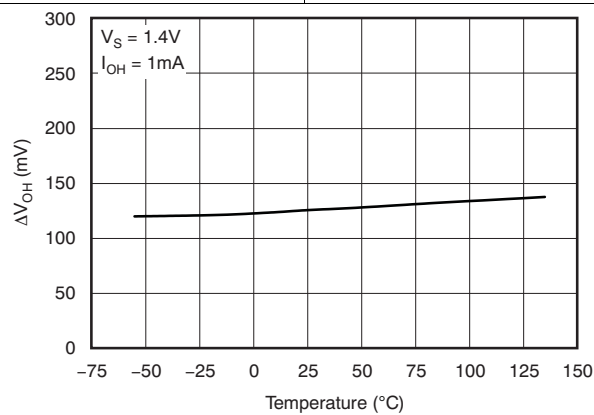

**Figure 9. Output Logic Level High vs Temperature**

## 8 Detailed Description

### 8.1 Overview

The TMP303 devices are temperature switches used in battery-powered applications that require accurate monitoring of a very specific temperature range from 0°C to 60°C (TMP303A), 0°C to 55°C (TMP303B), –20°C to 60°C (TMP303C) or –15°C to 125°C (TMP303D). This functionality is accomplished through the preset trip window and two hysteresis bits,  $\text{HYST}_{\text{SET}0}$  and  $\text{HYST}_{\text{SET}1}$ . The preset trip window temperature thresholds are configured at the factory; for other trip points, contact a TI representative. [Table 1](#) summarizes the bit setting versus hysteresis temperature window.

**Table 1. Bit Setting vs Hysteresis Window**

$\text{HYST}_{\text{SET}1}$	$\text{HYST}_{\text{SET}0}$	HYSTERESIS
GND	GND	1°C
GND	$V_S$	2°C
$V_S$	GND	5°C
$V_S$	$V_S$	10°C

### 8.2 Functional Block Diagram

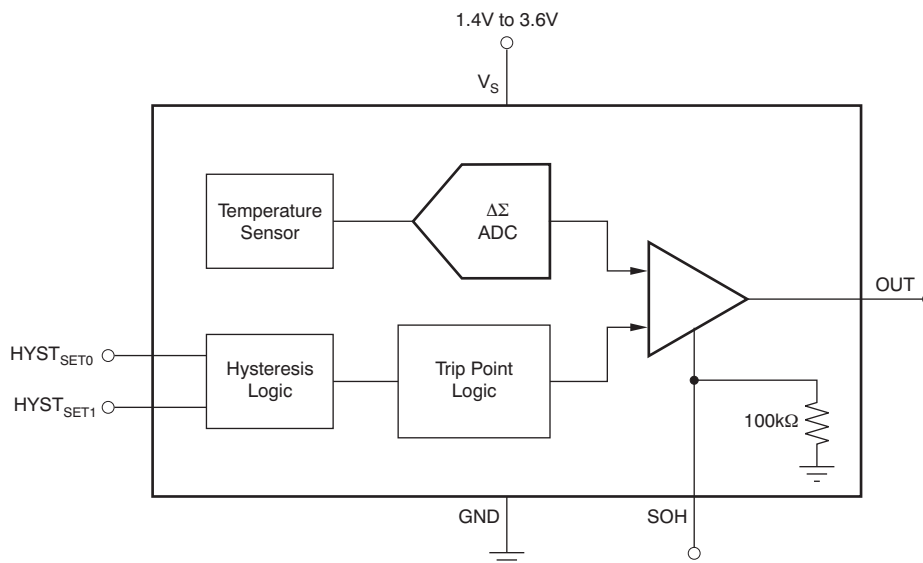

### 8.3 Feature Description

#### 8.3.1 HYST<sub>SET0</sub>, HYST<sub>SET1</sub> and SOH Functionality

The TMP303A temperature trip window resides within the range of 0°C to 60°C, the TMP303B within 0°C to 55°C, the TMP303C within –20°C to 60°C, and the TMP303D within –15°C to 125°C. When any of these trip thresholds is crossed, the output (OUT) changes state from low to high. OUT does not return to its original low state until the temperature crosses the hysteresis threshold and returns within the range of the temperature trip window.

As an example, if the TMP303A is configured with a 10°C hysteresis window (that is, HYST<sub>SET0</sub> = HYST<sub>SET1</sub> = V<sub>S</sub>), the output does not return to its low state until the temperature either crosses (T<sub>L</sub> + hysteresis) = 10°C or (T<sub>H</sub> – hysteresis) = 50°C. The Set Output High (SOH) pin is intended to add test functionality to verify the connectivity of the output (OUT) pin to the system controller or other temperature response system. The SOH pin is internally pulled down to ground with a 100-kΩ resistor. If the SOH pin is grounded or left floating, it has no effect on the behavior of the TMP303A. If the SOH pin is pulled high, the TMP303A immediately forces the output high, regardless of temperature.

**NOTE**

This response occurs even if the temperature falls within the 0°C to 60°C temperature window.

Figure 10 shows this design in graphical form.

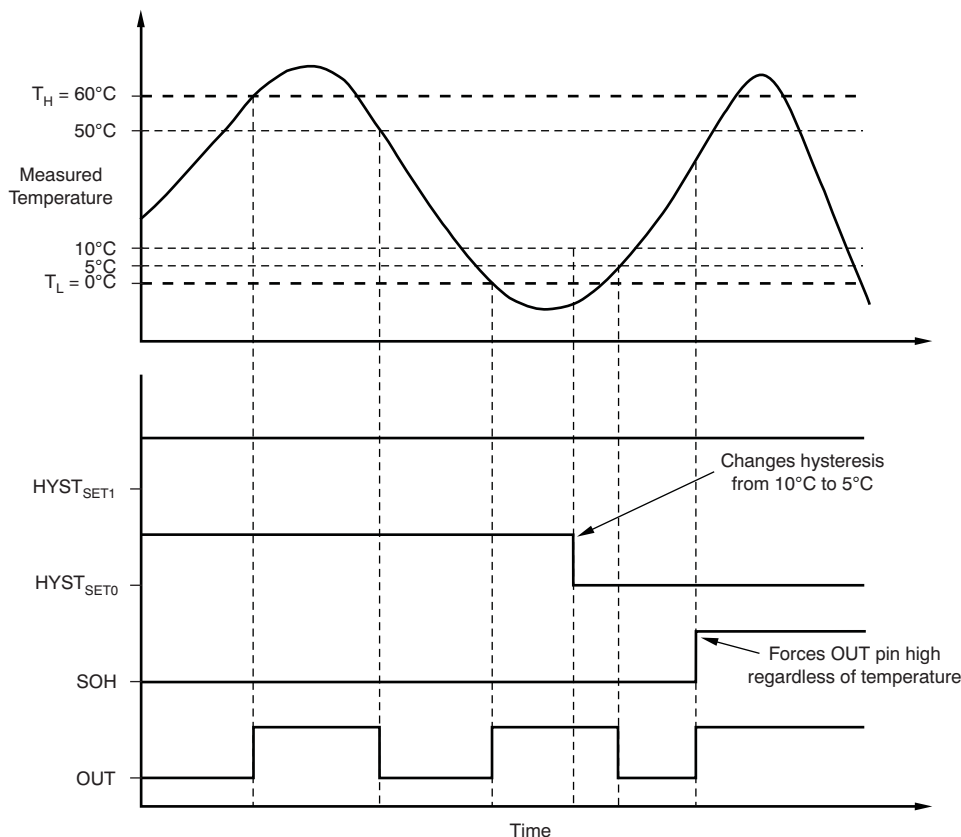

**Figure 10. TMP303A Output Transfer Curves With Hysteresis Change from 10°C to 5°C and SOH Functionality**

## Feature Description (continued)

### 8.3.2 TMP303 Power Up and Timing

At device power up, the TMP303 exerts  $OUT = \text{high}$ , and typically requires 26 ms to return to a low state only if the temperature falls within the hysteresis window set by  $HYST_{SET0}$  and  $HYST_{SET1}$ .

The tolerance of the thermal response time is largely a result of the differences in conversion time, which varies from 20 ms to 35 ms; likewise, this conversion does not take place after a power cycle until the supply voltage has reached a level of at least 1.4 V. This sequence is illustrated in Figure 11.

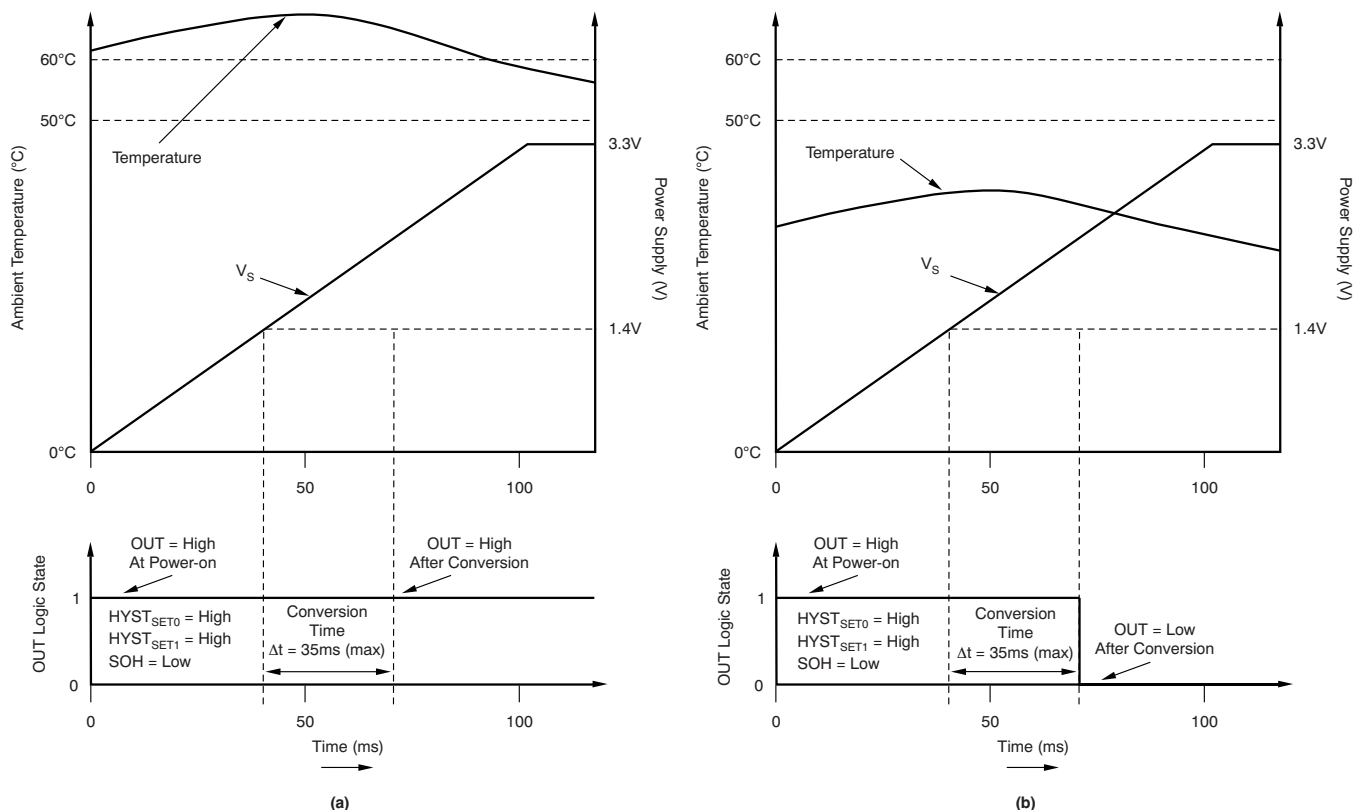
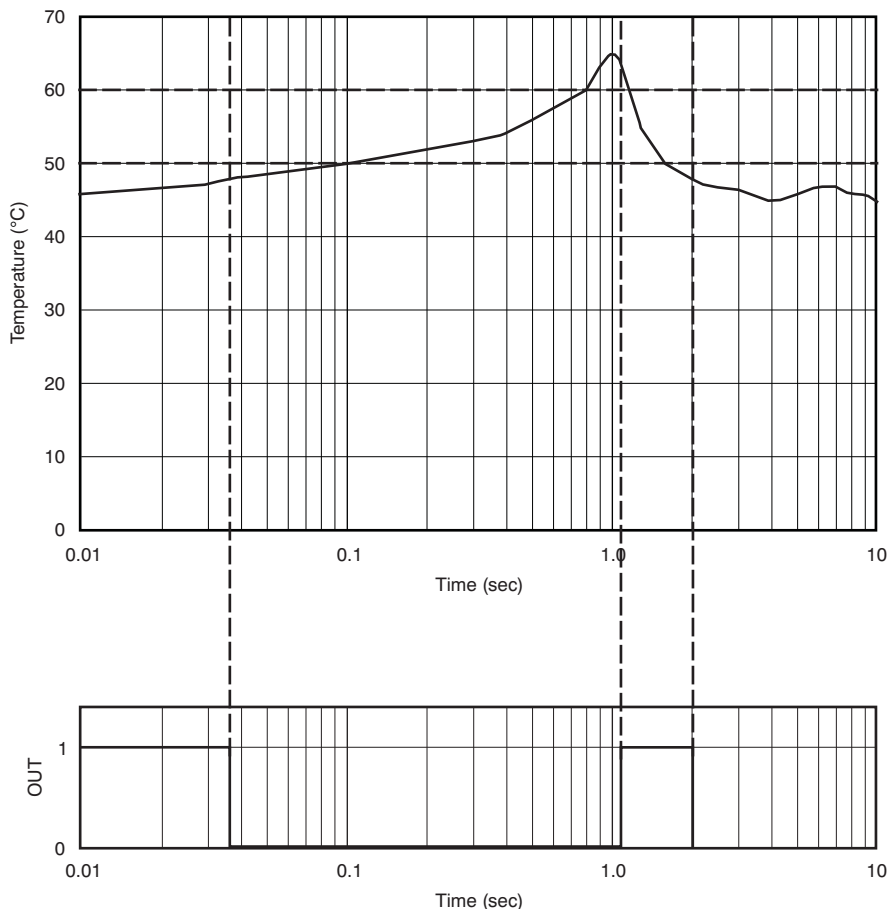

Figure 11. TMP303A Start-Up Delay vs Output Voltage ( $HYST_{SET0} = HYST_{SET1} = V_s$ )

After the TMP303 powers up, all successive thermal response results for the device are achieved in a time frame of 0.985 s to 1 s. This period is the minimum time frame required for the push-pull output (OUT) to change its state from high to low (or conversely) when the device is active.

**Feature Description (continued)**

A maximum low output voltage is defined as a voltage level equivalent to  $(0.2 \times V_S)$ ; likewise, a minimum high-output voltage is defined as  $(0.8 \times V_S)$ . The timing associated with start-up time and conversion is shown in Figure 12.



**Figure 12. TMP303A Start-Up and Conversion Timing ( $HYST_{SET0} = HYST_{SET1} = V_S$ )**

**8.4 Device Functional Modes**

The TMP303 family of devices has a single functional mode. Normal operation for the TMP303 family of devices occurs when the power-supply voltage applied between the  $V_S$  pin and GND is within the specified operating range of 1.4 to 3.6 V. The temperature threshold is configured at the factory and the hysteresis is selected by connecting the  $HYST_{SET0}$  and  $HYST_{SET1}$  pins to either the GND or  $V_S$  pins (see Table 1).

## 9 Application and Implementation

### NOTE

Information in the following applications sections is not part of the TI component specification, and TI does not warrant its accuracy or completeness. TI's customers are responsible for determining suitability of components for their purposes. Customers should validate and test their design implementation to confirm system functionality.

### 9.1 Application Information

The TMP303 family of devices is simple to configure. The TMP303 contains an active high, push-pull output stage and does not require a pullup resistor to  $V_S$  for proper operation. The only external component that the device requires is a bypass capacitor. TI strongly recommends using a 0.1- $\mu\text{F}$  capacitor, placed as close as possible to the supply pin.

### 9.2 Typical Applications

#### 9.2.1 TMP303 Typical Configuration

Figure 13 shows the typical circuit configuration for the TMP303 family of devices. These devices have preprogrammed trip-points. Select the TMP303 device that meets the application temperature trip requirement.

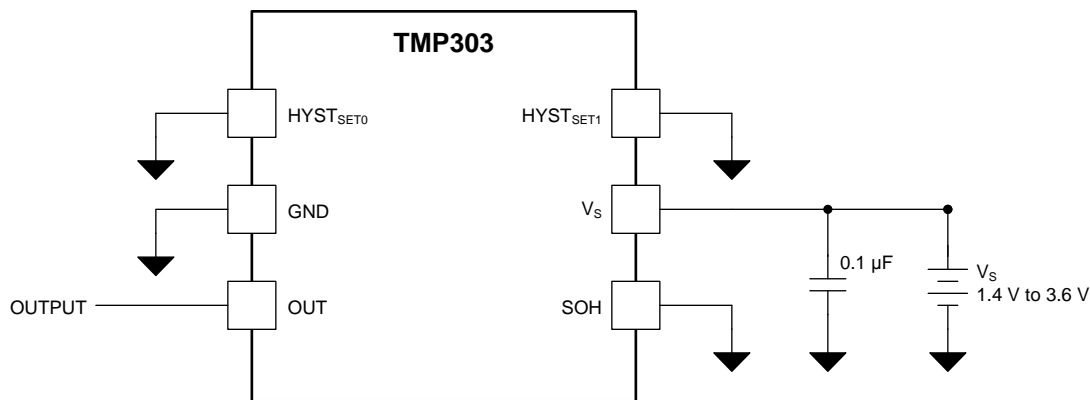

Figure 13. TMP303 Typical Application Configuration Schematic

#### 9.2.1.1 Design Requirements

The TMP303 is a temperature switch commonly used to signal a microprocessor in the event of an over or under temperature condition. The temperature that the TMP303 issues a output is determined by the device preset trip window. The TMP303 issues an output when the temperature threshold is exceeded. To avoid the TMP303 signaling the microprocessor as soon as the temperature drops below the temperature threshold the TMP303 has a built-in hysteresis. The amount of hysteresis is determined by the hysteresis pins,  $\text{HYST}_{\text{SET}0}$  and  $\text{HYST}_{\text{SET}1}$ . These pins are digital inputs and must be tied either high or low, according to Table 1.

#### 9.2.1.2 Detailed Design Procedure

Select the appropriate TMP303 device that matches the application requirements; see the [Device Options](#) table for different trip point ranges. Connect the  $\text{HYST}_{\text{SET}0}$  and  $\text{HYST}_{\text{SET}1}$  pins according to the application requirements; see Table 1. In Figure 13 the TMP303 device is configured with a 1°C hysteresis window (that is,  $\text{HYST}_{\text{SET}0} = \text{HYST}_{\text{SET}1} = \text{GND}$ ). Place a 0.1- $\mu\text{F}$  bypass capacitor close to the TMP303 device to reduce the noise coupled from the power supply.

## Typical Applications (continued)

### 9.2.1.3 Application Curves

Figure 14 and Figure 15 show the TMP303A power-on response with the ambient temperature ( $T_A$ ) less than 60°C and greater than 60°C respectively. TMP303B, TMP303C, and TMP303D devices behave similarly with regards to power-on response with  $T_A$  below or above the trip point.

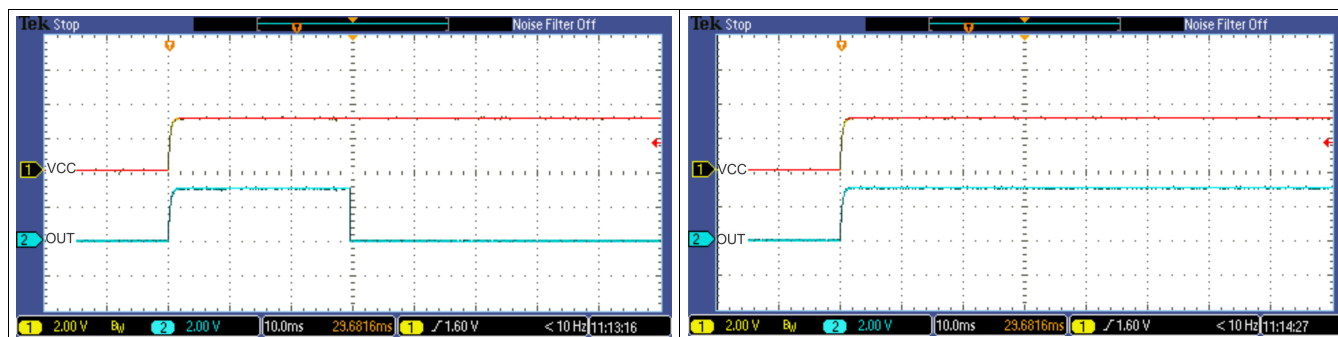

Figure 14. TMP303A Power-On Response,  $T_A$  Less Than 60°C

Figure 15. TMP303A Power-On Response,  $T_A$  Greater Than 60°C

### 9.2.2 TMP303 With Switches

Figure 16 shows the most generic implementation of the TMP303 family of devices. Switches are shown connecting the  $\text{HYST}_{\text{SET}0}$  and  $\text{HYST}_{\text{SET}1}$  pins to either  $V_S$  or GND. The use of switches is not a requirement; the switches are shown only to illustrate the various pin connection combinations. In practice, connecting the  $\text{HYST}_{\text{SET}0}$  and  $\text{HYST}_{\text{SET}1}$  pins to ground or directly to the  $V_S$  pin is sufficient and minimizes board space and cost. If additional flexibility is desired, connections from the  $\text{HYST}_{\text{SET}0}$  and  $\text{HYST}_{\text{SET}1}$  pins can be made through 0-Ω resistors, which can be either populated or not, depending upon the desired connection.

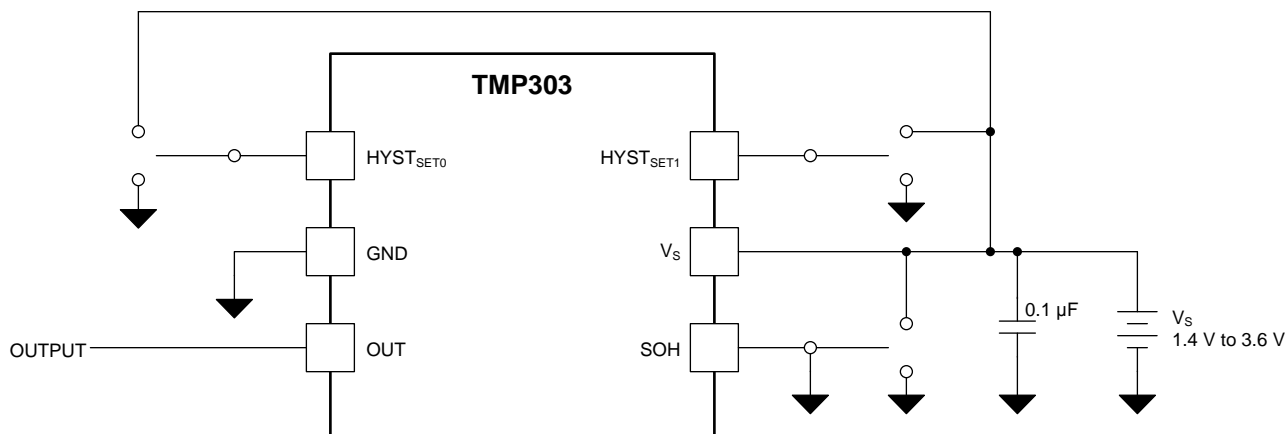
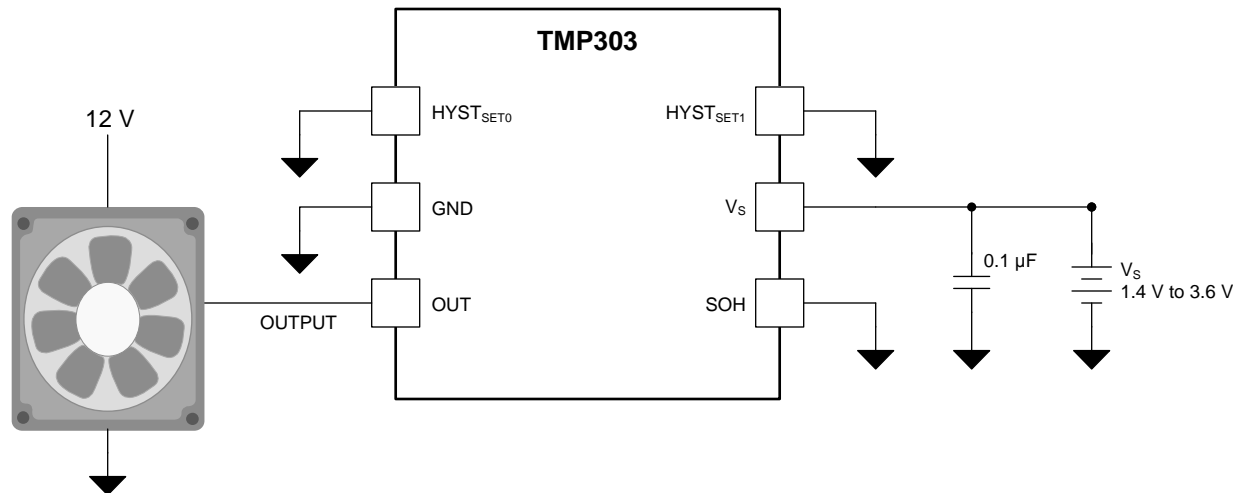

Figure 16. TMP303 With Switches

## Typical Applications (continued)

### 9.2.3 Simple Fan Controller

The circuit in [Figure 17](#) senses system temperature and turns a cooling fan on when the sensor's temperature exceeds a preselected value. The TMP303 device can be used directly to control the fan. The OUT pin is active high, and it can be used directly to drive the DC fan. When temperature is within the temperature limits of the system, the fan turns off, and when the temperature exceeds the trip-point, the fan turns on. In this example, the TMP303A device is used and is configured with a 1°C hysteresis window ( $\text{HYST}_{\text{SET}0} = \text{HYST}_{\text{SET}1} = \text{GND}$ ). The TMP303A high trip-point is 60°C. When this trip-point temperature is exceeded, the output (OUT) changes state from low to high. The output does not return to its low state until the temperature decreases below ( $T_H - \text{hysteresis}$ ) = 59°C.



**Figure 17. Simple Fan Controller**

## Typical Applications (continued)

### 9.2.4 Wireless Fixed Temperature Heat Detector

Heat detectors are needed in building automation. Conventional heat detectors need cables to supply power and send the information back to a central system. Adding cables can be very costly and technically challenging in old buildings, this leads to wireless battery operated heat detectors as preferred solutions. Running on battery requires designing a very low power system for long haul. TMP303 can be used to design a low power heat detector due to its very low quiescent current (5  $\mu$ A maximum). The TMP303 device does not require any additional components and can be interfaced with the MCU using only one GPIO. As an example, a wireless transceiver with internal MCU can be used to monitor the TMP303 and communicate with a central system or turn on an alarm in case of temperatures exceeding the trip-point. Figure 18 shows typical connections.

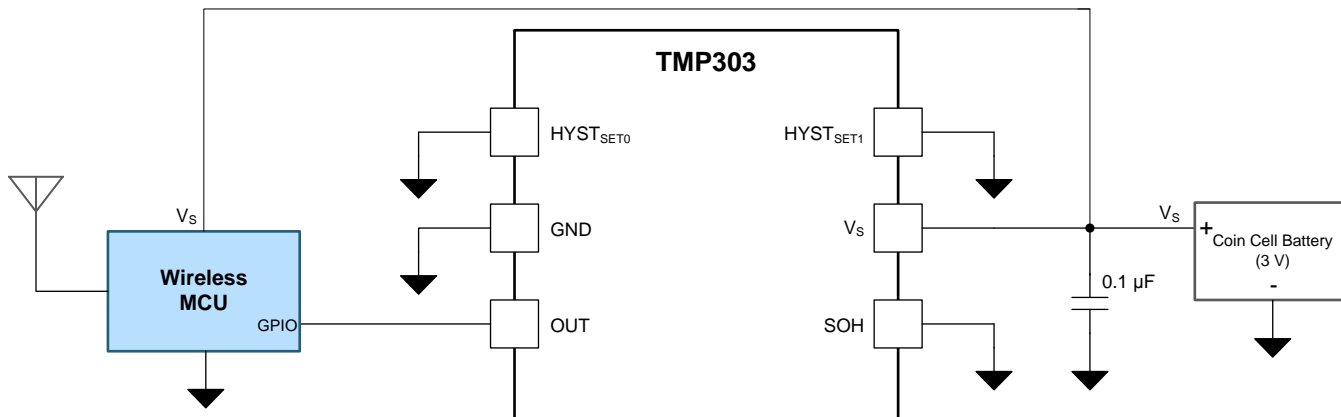

Figure 18. Wireless Fixed Temperature Heat Detector

## 10 Power Supply Recommendations

The TMP303 family of devices is designed to operate from a single power supply within the range of 1.4 V to 3.6 V. No specific power supply sequencing with respect to any of the input or output pins is required.

## 11 Layout

### 11.1 Layout Guidelines

Mount the TMP303 to a PCB as shown in [Figure 19](#). For this example the  $\text{HYST}_{\text{SET}0}$  and  $\text{HYST}_{\text{SET}1}$  pins are connected directly to ground. Connecting these pins to ground configures the device for 1°C hysteresis. The SOH pin is grounded in this layout. Leaving this pin floating has no effect on the behavior of the TMP303.

- Bypass the  $V_S$  pin to ground with a low-ESR ceramic bypass capacitor. The typical recommended bypass capacitance is a 0.1- $\mu\text{F}$  ceramic capacitor with a X5R or X7R dielectric. The optimum placement is closest to the  $V_S$  and GND pins of the device. Take care in minimizing the loop area formed by the bypass-capacitor connection, the  $V_S$  pin, and the GND pin of the IC. Additional bypass capacitance can be added to compensate for noisy or high-impedance power supplies.
- The OUT pin is a push-pull, active-high output and does not require a pullup resistor to  $V_S$ .

### 11.2 Layout Example

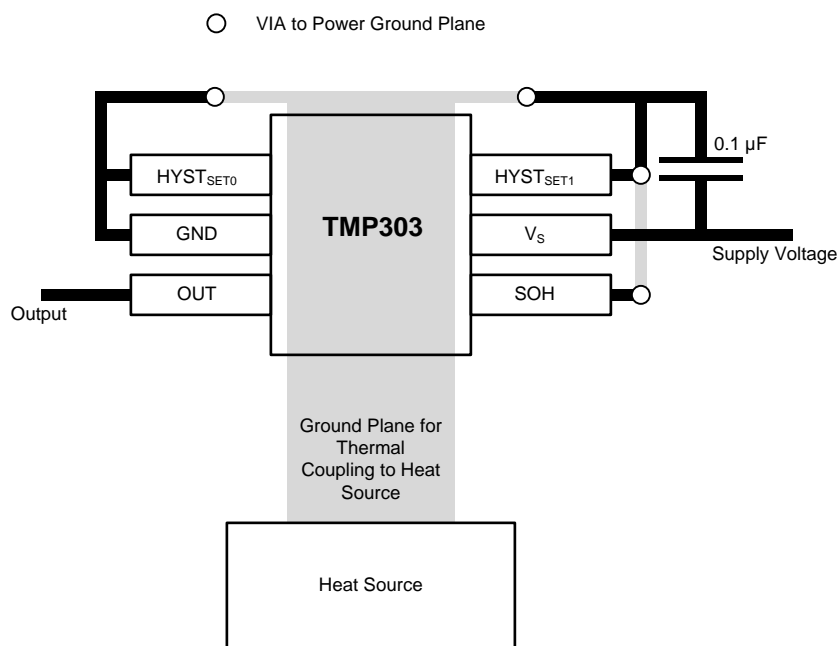

**Figure 19. PCB Layout Example**

## 12 Device and Documentation Support

### 12.1 Community Resources

The following links connect to TI community resources. Linked contents are provided "AS IS" by the respective contributors. They do not constitute TI specifications and do not necessarily reflect TI's views; see TI's [Terms of Use](#).

**TI E2E™ Online Community** *TI's Engineer-to-Engineer (E2E) Community*. Created to foster collaboration among engineers. At [e2e.ti.com](http://e2e.ti.com), you can ask questions, share knowledge, explore ideas and help solve problems with fellow engineers.

**Design Support** *TI's Design Support* Quickly find helpful E2E forums along with design support tools and contact information for technical support.

### 12.2 Trademarks

E2E is a trademark of Texas Instruments.  
All other trademarks are the property of their respective owners.

### 12.3 Electrostatic Discharge Caution



These devices have limited built-in ESD protection. The leads should be shorted together or the device placed in conductive foam during storage or handling to prevent electrostatic damage to the MOS gates.

### 12.4 Glossary

[SLYZ022](#) — *TI Glossary*.

This glossary lists and explains terms, acronyms, and definitions.

## 13 Mechanical, Packaging, and Orderable Information

The following pages include mechanical, packaging, and orderable information. This information is the most current data available for the designated devices. This data is subject to change without notice and revision of this document. For browser-based versions of this data sheet, refer to the left-hand navigation.

**PACKAGING INFORMATION**

Orderable Device	Status (1)	Package Type	Package Drawing	Pins	Package Qty	Eco Plan (2)	Lead/Ball Finish (6)	MSL Peak Temp (3)	Op Temp (°C)	Device Marking (4/5)	Samples
TMP303ADRLR	ACTIVE	SOT-OTHER	DRL	6	4000	Green (RoHS & no Sb/Br)	CU NIPDAU	Level-1-260C-UNLIM	-40 to 125	OCO	<a href="#">Samples</a>
TMP303ADRLT	ACTIVE	SOT-OTHER	DRL	6	250	Green (RoHS & no Sb/Br)	CU NIPDAU	Level-1-260C-UNLIM	-40 to 125	OCO	<a href="#">Samples</a>
TMP303BDRLR	ACTIVE	SOT-OTHER	DRL	6	4000	Green (RoHS & no Sb/Br)	CU NIPDAU	Level-1-260C-UNLIM		QWM	<a href="#">Samples</a>
TMP303BDRLT	ACTIVE	SOT-OTHER	DRL	6	250	Green (RoHS & no Sb/Br)	CU NIPDAU	Level-1-260C-UNLIM	-40 to 125	QWM	<a href="#">Samples</a>
TMP303CDRLR	ACTIVE	SOT-OTHER	DRL	6	4000	Green (RoHS & no Sb/Br)	CU NIPDAU	Level-1-260C-UNLIM	-40 to 125	11U	<a href="#">Samples</a>
TMP303CDRLT	ACTIVE	SOT-OTHER	DRL	6	250	Green (RoHS & no Sb/Br)	CU NIPDAU	Level-1-260C-UNLIM	-40 to 125	11U	<a href="#">Samples</a>
TMP303DDRLR	ACTIVE	SOT-OTHER	DRL	6	4000	Green (RoHS & no Sb/Br)	CU NIPDAU	Level-1-260C-UNLIM	-40 to 125	12Z	<a href="#">Samples</a>
TMP303DDRLT	ACTIVE	SOT-OTHER	DRL	6	250	Green (RoHS & no Sb/Br)	CU NIPDAU	Level-1-260C-UNLIM	-40 to 125	12Z	<a href="#">Samples</a>

(1) The marketing status values are defined as follows:

**ACTIVE:** Product device recommended for new designs.

**LIFEBUY:** TI has announced that the device will be discontinued, and a lifetime-buy period is in effect.

**NRND:** Not recommended for new designs. Device is in production to support existing customers, but TI does not recommend using this part in a new design.

**PREVIEW:** Device has been announced but is not in production. Samples may or may not be available.

**OBSOLETE:** TI has discontinued the production of the device.

(2) Eco Plan - The planned eco-friendly classification: Pb-Free (RoHS), Pb-Free (RoHS Exempt), or Green (RoHS & no Sb/Br) - please check <http://www.ti.com/productcontent> for the latest availability information and additional product content details.

**TBD:** The Pb-Free/Green conversion plan has not been defined.

**Pb-Free (RoHS):** TI's terms "Lead-Free" or "Pb-Free" mean semiconductor products that are compatible with the current RoHS requirements for all 6 substances, including the requirement that lead not exceed 0.1% by weight in homogeneous materials. Where designed to be soldered at high temperatures, TI Pb-Free products are suitable for use in specified lead-free processes.

**Pb-Free (RoHS Exempt):** This component has a RoHS exemption for either 1) lead-based flip-chip solder bumps used between the die and package, or 2) lead-based die adhesive used between the die and leadframe. The component is otherwise considered Pb-Free (RoHS compatible) as defined above.

**Green (RoHS & no Sb/Br):** TI defines "Green" to mean Pb-Free (RoHS compatible), and free of Bromine (Br) and Antimony (Sb) based flame retardants (Br or Sb do not exceed 0.1% by weight in homogeneous material)

(3) MSL, Peak Temp. - The Moisture Sensitivity Level rating according to the JEDEC industry standard classifications, and peak solder temperature.

(4) There may be additional marking, which relates to the logo, the lot trace code information, or the environmental category on the device.

(5) Multiple Device Markings will be inside parentheses. Only one Device Marking contained in parentheses and separated by a "~" will appear on a device. If a line is indented then it is a continuation of the previous line and the two combined represent the entire Device Marking for that device.

(6) Lead/Ball Finish - Orderable Devices may have multiple material finish options. Finish options are separated by a vertical ruled line. Lead/Ball Finish values may wrap to two lines if the finish value exceeds the maximum column width.

**Important Information and Disclaimer:**The information provided on this page represents TI's knowledge and belief as of the date that it is provided. TI bases its knowledge and belief on information provided by third parties, and makes no representation or warranty as to the accuracy of such information. Efforts are underway to better integrate information from third parties. TI has taken and continues to take reasonable steps to provide representative and accurate information but may not have conducted destructive testing or chemical analysis on incoming materials and chemicals. TI and TI suppliers consider certain information to be proprietary, and thus CAS numbers and other limited information may not be available for release.

In no event shall TI's liability arising out of such information exceed the total purchase price of the TI part(s) at issue in this document sold by TI to Customer on an annual basis.

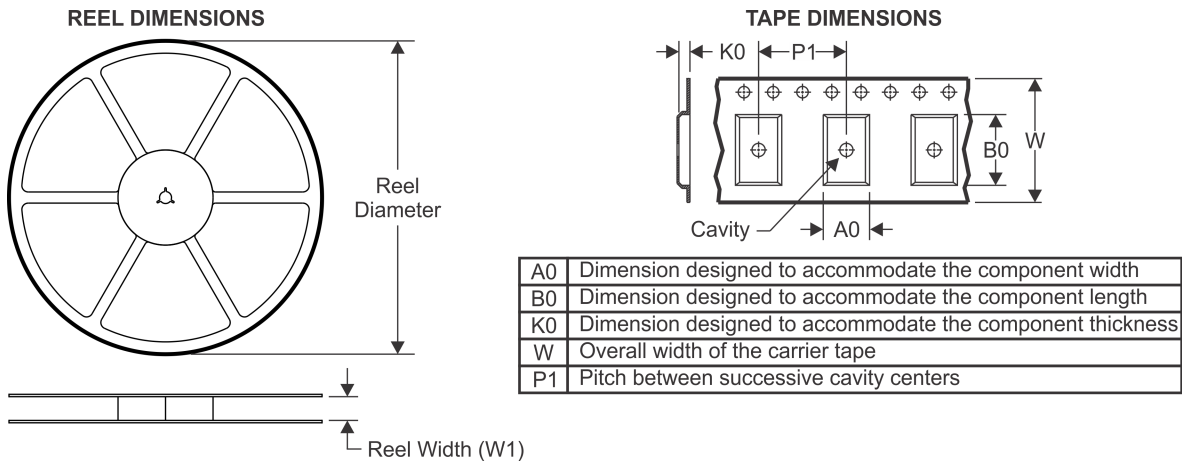
**TAPE AND REEL INFORMATION**

**QUADRANT ASSIGNMENTS FOR PIN 1 ORIENTATION IN TAPE**

\*All dimensions are nominal

Device	Package Type	Package Drawing	Pins	SPQ	Reel Diameter (mm)	Reel Width W1 (mm)	A0 (mm)	B0 (mm)	K0 (mm)	P1 (mm)	W (mm)	Pin1 Quadrant
TMP303ADRLR	SOT-OTHER	DRL	6	4000	180.0	9.5	1.78	1.78	0.69	4.0	8.0	Q3
TMP303ADRLR	SOT-OTHER	DRL	6	4000	180.0	8.4	1.98	1.78	0.69	4.0	8.0	Q3
TMP303ADRLT	SOT-OTHER	DRL	6	250	180.0	8.4	1.98	1.78	0.69	4.0	8.0	Q3
TMP303ADRLT	SOT-OTHER	DRL	6	250	180.0	9.5	1.78	1.78	0.69	4.0	8.0	Q3
TMP303BDRLR	SOT-OTHER	DRL	6	4000	180.0	9.5	1.78	1.78	0.69	4.0	8.0	Q3
TMP303BDRLR	SOT-OTHER	DRL	6	4000	180.0	8.4	1.98	1.78	0.69	4.0	8.0	Q3
TMP303BDRLT	SOT-OTHER	DRL	6	250	180.0	8.4	1.98	1.78	0.69	4.0	8.0	Q3
TMP303BDRLT	SOT-OTHER	DRL	6	250	180.0	9.5	1.78	1.78	0.69	4.0	8.0	Q3
TMP303CDRLR	SOT-OTHER	DRL	6	4000	180.0	9.5	1.78	1.78	0.69	4.0	8.0	Q3
TMP303CDRLT	SOT-OTHER	DRL	6	250	180.0	9.5	1.78	1.78	0.69	4.0	8.0	Q3
TMP303DDRLR	SOT-	DRL	6	4000	180.0	9.5	1.78	1.78	0.69	4.0	8.0	Q3

Device	Package Type	Package Drawing	Pins	SPQ	Reel Diameter (mm)	Reel Width W1 (mm)	A0 (mm)	B0 (mm)	K0 (mm)	P1 (mm)	W (mm)	Pin1 Quadrant
	OTHER											
TMP303DDRLT	SOT-OTHER	DRL	6	250	180.0	9.5	1.78	1.78	0.69	4.0	8.0	Q3

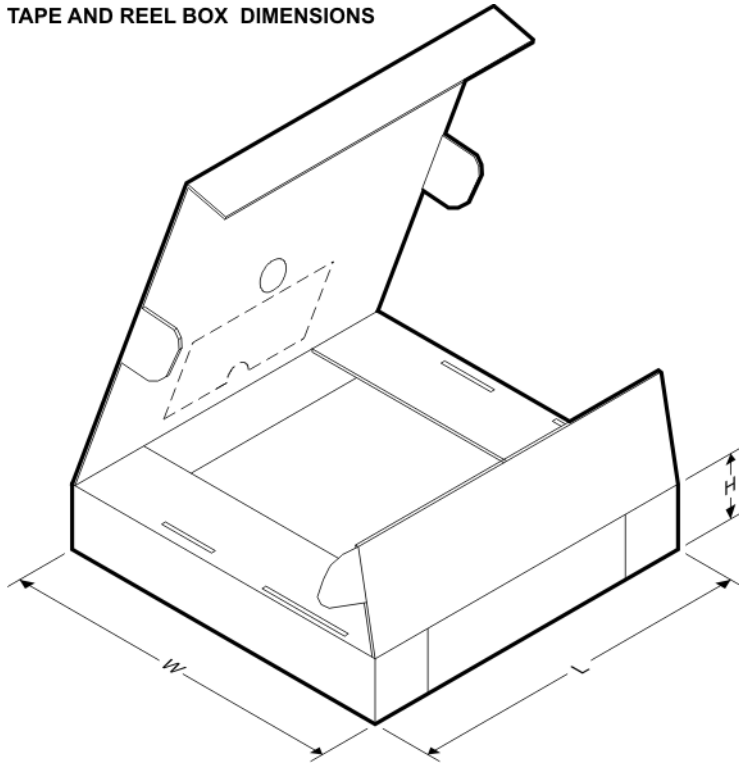
## TAPE AND REEL BOX DIMENSIONS



\*All dimensions are nominal

Device	Package Type	Package Drawing	Pins	SPQ	Length (mm)	Width (mm)	Height (mm)
TMP303ADRLR	SOT-OTHER	DRL	6	4000	184.0	184.0	19.0
TMP303ADRLR	SOT-OTHER	DRL	6	4000	202.0	201.0	28.0
TMP303ADRLT	SOT-OTHER	DRL	6	250	202.0	201.0	28.0
TMP303ADRLT	SOT-OTHER	DRL	6	250	184.0	184.0	19.0
TMP303BDRLR	SOT-OTHER	DRL	6	4000	184.0	184.0	19.0
TMP303BDRLR	SOT-OTHER	DRL	6	4000	202.0	201.0	28.0
TMP303BDRLT	SOT-OTHER	DRL	6	250	202.0	201.0	28.0
TMP303BDRLT	SOT-OTHER	DRL	6	250	184.0	184.0	19.0
TMP303CDRLR	SOT-OTHER	DRL	6	4000	184.0	184.0	19.0
TMP303CDRLT	SOT-OTHER	DRL	6	250	184.0	184.0	19.0
TMP303DDRLR	SOT-OTHER	DRL	6	4000	184.0	184.0	19.0
TMP303DDRLT	SOT-OTHER	DRL	6	250	184.0	184.0	19.0

DRL (R-PDSO-N6)

PLASTIC SMALL OUTLINE

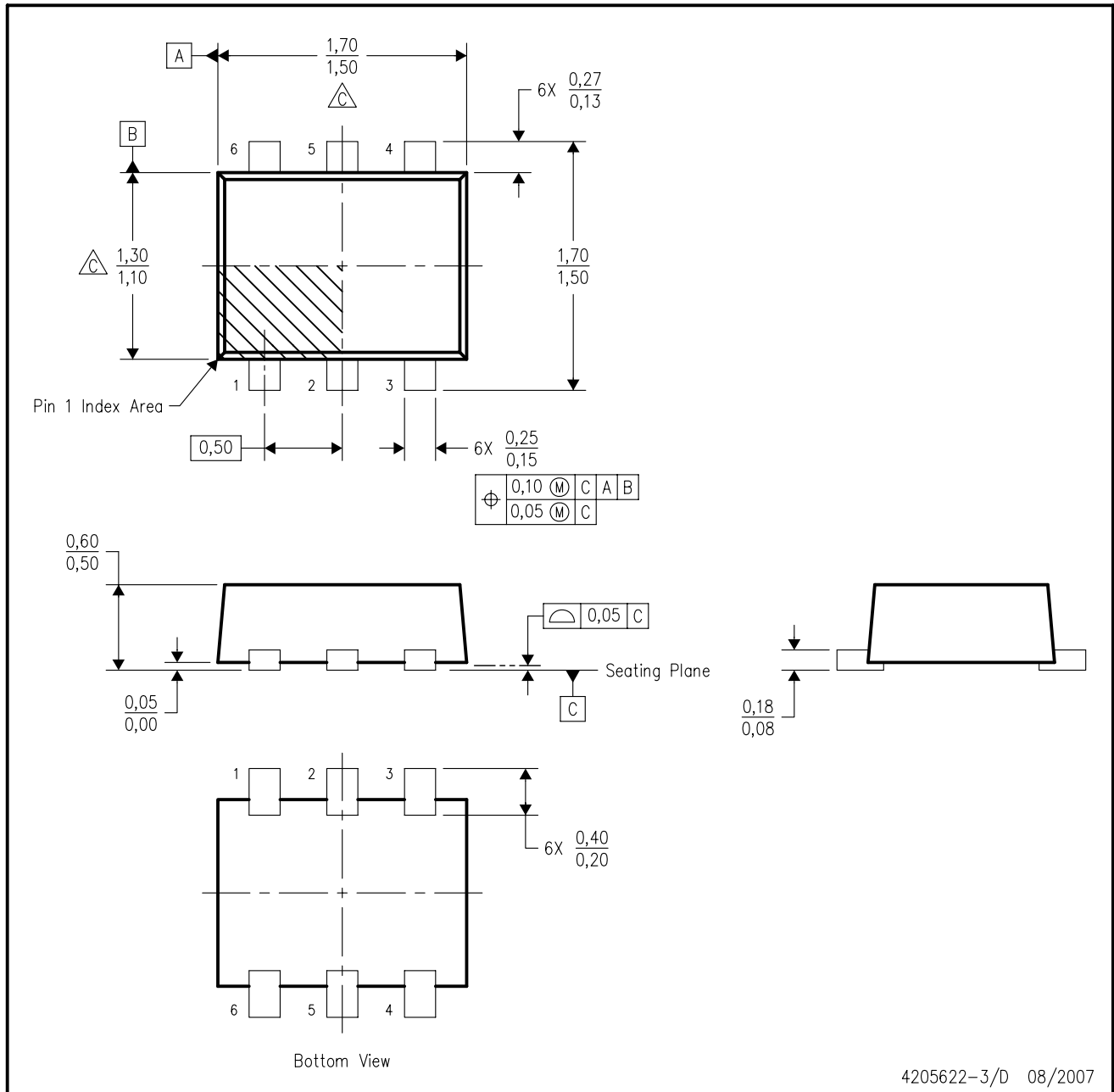

- NOTES:
- A. All linear dimensions are in millimeters. Dimensioning and tolerancing per ASME Y14.5M-1994.
  - B. This drawing is subject to change without notice.
  - C. Body dimensions do not include mold flash, interlead flash, protrusions, or gate burrs. Mold flash, interlead flash, protrusions, or gate burrs shall not exceed 0,15 per end or side.
  - D. JEDEC package registration is pending.

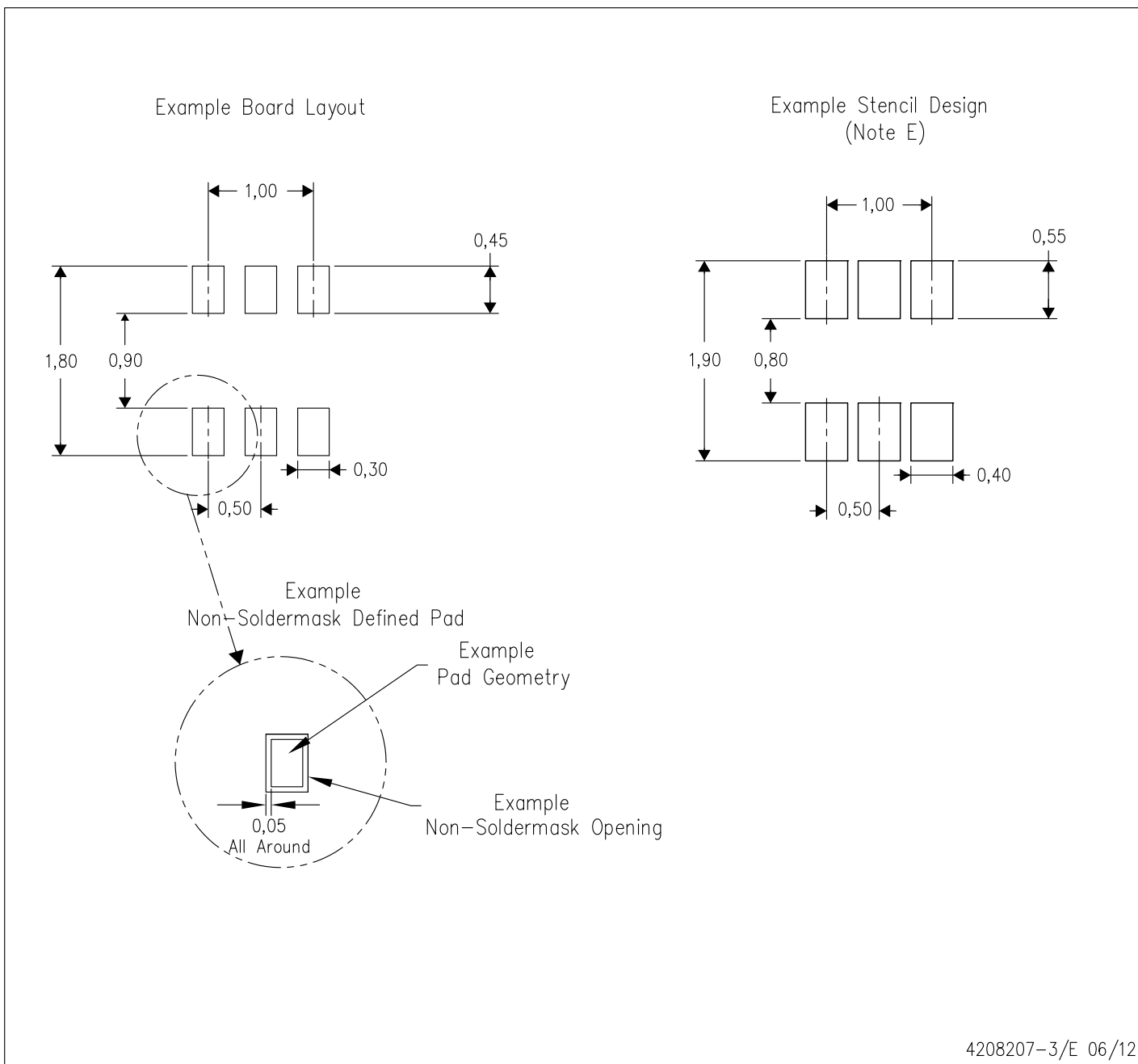

- NOTES:
- A. All linear dimensions are in millimeters.
  - B. This drawing is subject to change without notice.
  - C. Publication IPC-7351 is recommended for alternate designs.
  - D. Customers should contact their board fabrication site for minimum solder mask web tolerances between signal pads.
  - E. Maximum stencil thickness 0,127 mm (5 mils). All linear dimensions are in millimeters.
  - F. Laser cutting apertures with trapezoidal walls and also rounding corners will offer better paste release. Customers should contact their board assembly site for stencil design recommendations. Refer to IPC 7525 for stencil design considerations.
  - G. Side aperture dimensions over-print land for acceptable area ratio > 0.66. Customer may reduce side aperture dimensions if stencil manufacturing process allows for sufficient release at smaller opening.

## IMPORTANT NOTICE

Texas Instruments Incorporated (TI) reserves the right to make corrections, enhancements, improvements and other changes to its semiconductor products and services per JESD46, latest issue, and to discontinue any product or service per JESD48, latest issue. Buyers should obtain the latest relevant information before placing orders and should verify that such information is current and complete.

TI's published terms of sale for semiconductor products (<http://www.ti.com/sc/docs/stdterms.htm>) apply to the sale of packaged integrated circuit products that TI has qualified and released to market. Additional terms may apply to the use or sale of other types of TI products and services.

Reproduction of significant portions of TI information in TI data sheets is permissible only if reproduction is without alteration and is accompanied by all associated warranties, conditions, limitations, and notices. TI is not responsible or liable for such reproduced documentation. Information of third parties may be subject to additional restrictions. Resale of TI products or services with statements different from or beyond the parameters stated by TI for that product or service voids all express and any implied warranties for the associated TI product or service and is an unfair and deceptive business practice. TI is not responsible or liable for any such statements.

Buyers and others who are developing systems that incorporate TI products (collectively, "Designers") understand and agree that Designers remain responsible for using their independent analysis, evaluation and judgment in designing their applications and that Designers have full and exclusive responsibility to assure the safety of Designers' applications and compliance of their applications (and of all TI products used in or for Designers' applications) with all applicable regulations, laws and other applicable requirements. Designer represents that, with respect to their applications, Designer has all the necessary expertise to create and implement safeguards that (1) anticipate dangerous consequences of failures, (2) monitor failures and their consequences, and (3) lessen the likelihood of failures that might cause harm and take appropriate actions. Designer agrees that prior to using or distributing any applications that include TI products, Designer will thoroughly test such applications and the functionality of such TI products as used in such applications.

TI's provision of technical, application or other design advice, quality characterization, reliability data or other services or information, including, but not limited to, reference designs and materials relating to evaluation modules, (collectively, "TI Resources") are intended to assist designers who are developing applications that incorporate TI products; by downloading, accessing or using TI Resources in any way, Designer (individually or, if Designer is acting on behalf of a company, Designer's company) agrees to use any particular TI Resource solely for this purpose and subject to the terms of this Notice.

TI's provision of TI Resources does not expand or otherwise alter TI's applicable published warranties or warranty disclaimers for TI products, and no additional obligations or liabilities arise from TI providing such TI Resources. TI reserves the right to make corrections, enhancements, improvements and other changes to its TI Resources. TI has not conducted any testing other than that specifically described in the published documentation for a particular TI Resource.

Designer is authorized to use, copy and modify any individual TI Resource only in connection with the development of applications that include the TI product(s) identified in such TI Resource. NO OTHER LICENSE, EXPRESS OR IMPLIED, BY ESTOPPEL OR OTHERWISE TO ANY OTHER TI INTELLECTUAL PROPERTY RIGHT, AND NO LICENSE TO ANY TECHNOLOGY OR INTELLECTUAL PROPERTY RIGHT OF TI OR ANY THIRD PARTY IS GRANTED HEREIN, including but not limited to any patent right, copyright, mask work right, or other intellectual property right relating to any combination, machine, or process in which TI products or services are used. Information regarding or referencing third-party products or services does not constitute a license to use such products or services, or a warranty or endorsement thereof. Use of TI Resources may require a license from a third party under the patents or other intellectual property of the third party, or a license from TI under the patents or other intellectual property of TI.

TI RESOURCES ARE PROVIDED "AS IS" AND WITH ALL FAULTS. TI DISCLAIMS ALL OTHER WARRANTIES OR REPRESENTATIONS, EXPRESS OR IMPLIED, REGARDING RESOURCES OR USE THEREOF, INCLUDING BUT NOT LIMITED TO ACCURACY OR COMPLETENESS, TITLE, ANY EPIDEMIC FAILURE WARRANTY AND ANY IMPLIED WARRANTIES OF MERCHANTABILITY, FITNESS FOR A PARTICULAR PURPOSE, AND NON-INFRINGEMENT OF ANY THIRD PARTY INTELLECTUAL PROPERTY RIGHTS. TI SHALL NOT BE LIABLE FOR AND SHALL NOT DEFEND OR INDEMNIFY DESIGNER AGAINST ANY CLAIM, INCLUDING BUT NOT LIMITED TO ANY INFRINGEMENT CLAIM THAT RELATES TO OR IS BASED ON ANY COMBINATION OF PRODUCTS EVEN IF DESCRIBED IN TI RESOURCES OR OTHERWISE. IN NO EVENT SHALL TI BE LIABLE FOR ANY ACTUAL, DIRECT, SPECIAL, COLLATERAL, INDIRECT, PUNITIVE, INCIDENTAL, CONSEQUENTIAL OR EXEMPLARY DAMAGES IN CONNECTION WITH OR ARISING OUT OF TI RESOURCES OR USE THEREOF, AND REGARDLESS OF WHETHER TI HAS BEEN ADVISED OF THE POSSIBILITY OF SUCH DAMAGES.

Unless TI has explicitly designated an individual product as meeting the requirements of a particular industry standard (e.g., ISO/TS 16949 and ISO 26262), TI is not responsible for any failure to meet such industry standard requirements.

Where TI specifically promotes products as facilitating functional safety or as compliant with industry functional safety standards, such products are intended to help enable customers to design and create their own applications that meet applicable functional safety standards and requirements. Using products in an application does not by itself establish any safety features in the application. Designers must ensure compliance with safety-related requirements and standards applicable to their applications. Designer may not use any TI products in life-critical medical equipment unless authorized officers of the parties have executed a special contract specifically governing such use. Life-critical medical equipment is medical equipment where failure of such equipment would cause serious bodily injury or death (e.g., life support, pacemakers, defibrillators, heart pumps, neurostimulators, and implantables). Such equipment includes, without limitation, all medical devices identified by the U.S. Food and Drug Administration as Class III devices and equivalent classifications outside the U.S.

TI may expressly designate certain products as completing a particular qualification (e.g., Q100, Military Grade, or Enhanced Product). Designers agree that it has the necessary expertise to select the product with the appropriate qualification designation for their applications and that proper product selection is at Designers' own risk. Designers are solely responsible for compliance with all legal and regulatory requirements in connection with such selection.

Designer will fully indemnify TI and its representatives against any damages, costs, losses, and/or liabilities arising out of Designer's non-compliance with the terms and provisions of this Notice.